

Certification Examination

# Study Guide

Plant Maintenance  
Technologist  
Grade I





# Grade I Plant Maintenance Technologist Study Guide

Copyright © 2001 California Water Environment Association, Incorporated All Rights Reserved.  
2nd Printing April 2003

No part of this book may be reproduced without written permission from California Water Environment Association.



## Technical Content by CGvL Engineers

6 Hughes, Suite 100  
Irvine, CA 92618  
www.cgvl.com



### CGvL Project Team

Richard W. von Langen . . . . .	CGvL Project Manager
John Kennedy . . . . .	CGvL Editor
Steve Taylor . . . . .	Author
Bob Snyder . . . . .	Author
Dr. Kenneth D. Kerri . . . . .	Technical Editor
Carol Anderson-Serry . . . . .	Technical Editor
Rhonda Barkey . . . . .	Word Processing Group
Jessie Lee . . . . .	Word Processing Group
Joy Gautier . . . . .	Word Processing Group
Lisa House . . . . .	Word Processing Group

### Appendix A: You and Wastewater Math

Cheryl Ooten . . . . . Author

### CWEA Project Team

Chris Lundeen . . . . .	CWEA Project Manager/Editor
Nicole Schlosser . . . . .	Editing Assistance
Lindsay Roberts . . . . .	Project Support

### CWEA Technical Content Review

Eduardo Rosette . . . . .	San Francisco Public Utilities Commission
Dick Lindgren . . . . .	Central Marin Sanitation Agency
Kit Groves . . . . .	Central Marin Sanitation Agency
James Kyser . . . . .	Sewer Authority Mid-Coastline
Bill Cronin . . . . .	Monterey Regional Water Pollution Control Agency

Cover Photo . . . . . Courtesy of Orange County Sanitation District

**Important Notice:** CWEA is pleased that you have purchased this book. We want to remind you that this book is one of many resources available to assist you, and we encourage you to identify and utilize the other resources in preparing for your next test.

Please send comments, questions, and suggestions to:

California Water Environment Association  
7677 Oakport Street, Suite 600  
Oakland, CA 94621 USA

Phone: 510-382-7800

Fax: 510-382-7810

Web: <http://www.cwea.org>

Email: [tcp@cwea.org](mailto:tcp@cwea.org)

# Grade I Plant Maintenance Technologist Study Guide

## Table of Contents

<b>1</b>	<b>Introduction .....</b>	<b>1</b>
<b>2</b>	<b>Certification Program Information and Policies .....</b>	<b>3</b>
	<b>Technical Certification Program History .....</b>	<b>3</b>
	<b>Certification Process .....</b>	<b>3</b>
	<b>Test Administration .....</b>	<b>3</b>
	<b>Test Dates and Sites .....</b>	<b>3</b>
	<b>Test Site Admission .....</b>	<b>4</b>
	<b>Test Security .....</b>	<b>4</b>
	<b>Test Postponement and Cancellation .....</b>	<b>4</b>
	<b>Test Result Notification .....</b>	<b>4</b>
	<b>Issue of Certificate .....</b>	<b>4</b>
	<b>Certificate Renewal .....</b>	<b>4</b>
	<b>Accommodations for Physical or Learning Disabilities .....</b>	<b>4</b>
	<b>Test Design and Format .....</b>	<b>4</b>
	<b>Test Design .....</b>	<b>4</b>
	<b>Test Delivery Mechanism .....</b>	<b>5</b>
	<b>Test Format .....</b>	<b>5</b>
	<b>Test Pass Point .....</b>	<b>5</b>
	<b>How Pass Points are Set .....</b>	<b>5</b>
	<b>Why Use Modified Angoff? .....</b>	<b>5</b>
	<b>Test Scoring .....</b>	<b>6</b>
	<b>Item Appeals .....</b>	<b>6</b>
	<b>Item Appeals .....</b>	<b>6</b>
	<b>Qualifying for the Test .....</b>	<b>6</b>
	<b>Essential Duties .....</b>	<b>6</b>
<b>3</b>	<b>Skill Sets.....</b>	<b>9</b>
	<b>Skill Set 1: Safety.....</b>	<b>9</b>
	<b>1.1 General.....</b>	<b>9</b>
	<b>1.2 Confined Space .....</b>	<b>9</b>
	<b>1.3 Chemical and Biological Hazards.....</b>	<b>9</b>
	<b>1.4 Material Safety Data Sheets (MSDS) .....</b>	<b>9</b>
	<b>1.5 Tool and Equipment Safety .....</b>	<b>10</b>
	<b>1.6 Machinery Safety .....</b>	<b>10</b>
	<b>1.7 Other .....</b>	<b>10</b>
	<b>Skill Set 2: Tools and Equipment.....</b>	<b>10</b>
	<b>2.1 Hand Tools and Equipment .....</b>	<b>10</b>
	<b>2.2 Power Tools and Instruments .....</b>	<b>11</b>
	<b>2.3 Heavy Equipment and Vehicles .....</b>	<b>11</b>
	<b>Skill Set 3: Maintenance, Repair, and Inspection .....</b>	<b>11</b>



## Table of Contents

	3.1 Maintenance Fundamentals .....	11
	3.2 Drawings and Prints .....	11
	3.3 Shop Math .....	11
	3.4 Metalworking .....	11
	3.5 Troubleshooting .....	11
	Skill Set 4: Communications and Interpersonal Relations.....	12
	Table 3-1 Grade I Plant Maintenance Technologist Primary References	13
<b>4</b>	<b>Test Preparation .....</b>	<b>15</b>
	Basic Study Strategy.....	15
	Multiple Choice Questions .....	15
	Table 4-1 Plant Maintenance Technologist Equivalents and Formulas...	16
	Math Problems .....	17
	Calculators .....	17
	Approach.....	18
	Solutions .....	18
	Equivalents and Formulas .....	18
	Dimensional Analysis.....	18
	Sample Questions .....	19
	Math Skills .....	19
	Arithmetic .....	19
	Geometry.....	20
<b>5</b>	<b>Diagnostic Test.....</b>	<b>21</b>
	Introduction .....	21
	Skill Set 1: Safety.....	21
	Skill Set 2: Tools and Equipment.....	21
	Skill Set 3: Maintenance, Repair, and Inspection .....	22
	Skill Set 4: Communications and Interpersonal Relations.....	24
	Test Answer Key .....	24
	Skill Set 1: Safety.....	24
	Skill Set 2: Tools and Equipment.....	24
	Skill Set 3: Maintenance, Repair and Inspection .....	24
	Skill Set 4: Communications and Interpersonal Relations.....	25
	Selected Problem Solutions .....	25
	Skill Set 3: Maintenance, Repair, and Inspection .....	25
<b>6</b>	<b>References.....</b>	<b>29</b>
	Primary References.....	29
	Secondary References.....	29
<b>A</b>	<b>Appendix: You and Wastewater Math .....</b>	<b>31</b>
	Introduction .....	31
	Two Facts to Consider .....	31
	Move Beyond the Math You Know .....	31
	Practice Problem Solving Strategies .....	33



**Units and Arithmetic..... 33**  
**Example Problems ..... 34**  
**Take Charge of Your Success ..... 36**  
**Recommendations ..... 36**  
**Test-Taking Strategies ..... 37**  
**Before the Exam ..... 37**  
**At the Exam ..... 38**  
**Negative Thinking About Exams ..... 39**  
**B Appendix: Glossary of Technical Terms .....41**  
**C Appendix: Common Acronyms and Abbreviations .....47**



# S e c t i o n 1

## Introduction

The California Water Environment Association (CWEA) Technical Certification Program (TCP) is voluntary; its purpose is to educate, prepare, and test an individual's knowledge within six vocations.

- Plant Maintenance Technology (with two parallel specialties in Electrical/ Instrumentation and Mechanical Technology)
- Laboratory Analysis
- Collection System Maintenance Technology
- Environmental Compliance Inspection
- Industrial Waste Treatment Plant Operations
- Biosolids Land Application Management

CWEA also assists in educating and training wastewater treatment plant operators for the State of California Operator Certification Tests. Upon qualifying and successfully completing a test, an individual is certified in that specialty at one of the grade levels. Levels within a specialty designate technical knowledge for the apprentice, journey, and management levels. Tests are designed to demonstrate minimum competence for a particular grade.

The purpose of this study guide is to provide a description of the knowledge, skills, and abilities (KSA) needed to pass the test. Also included are questions designed to assess candidates' strengths and weaknesses relative to their present KSA. Finally, the study guide provides references used to refresh subject knowledge, or to learn more about particular subject areas not completely understood.

Typically there are two to five primary references for each specialty area, which need to be read and understood. Test questions are generally based on information contained in these references. Secondary references give more information and often provide a different approach to a subject, making it easier to understand.

This study guide is not a compendium of all that may be on the test, so successfully answering questions contained in this guide does not guarantee passing. To successfully pass the Grade I

Plant Maintenance Technologist test, the reference materials presented in this study guide should be thoroughly understood.

This study guide can best be used to help identify strengths and weaknesses and to identify material that may need further study. Comments and suggestions to improve the study guide are always welcome and appreciated. Good luck on the test!



## Certification Program Information and Policies

CWEA's mission is to enhance the education and effectiveness of California wastewater professionals through training, certification, dissemination of technical information, and promotion of sound policies to benefit society through protection and enhancement of the water environment.

CWEA is a California nonprofit corporation, a Member Association of the Water Environment Federation (WEF), and a member of the National Organization for Competency Assurance (NOCA).

### Technical Certification Program History

TCP was created to offer multilevel technical certification for individuals employed in the water quality field. Tests are written by vocational specialists and administered throughout the year in six different disciplines: Plant Maintenance Technology (with two parallel specialties in Electrical/Instrumentation and Mechanical Technology), Laboratory Analysis, Collection System Maintenance Technology, Environmental Compliance Inspection, Industrial Waste Treatment Plant Operation, and Biosolids Land Application Management.

CWEA first offered a certification program for wastewater treatment plant operators in 1937. The program was administered by CWEA until 1973 when the State of California assumed responsibility. During those 36 years, CWEA awarded 3,915 operator certificates.

The first committees were formed in 1975 to establish a voluntary certification program for water quality professionals specializing in disciplines other than plant operation. The Voluntary Certification Program (VCP) emerged offering specialized certificate programs for Collection System Maintenance Technology, Plant Maintenance Technology, Environmental Compliance Inspection, and Laboratory Analysis, with certifications first issued in April 1976. In the 1980s, two more disciplines were added: Electrical/Instrumentation and Industrial Waste Treatment Plant Operations.

Today, CWEA offers certification in six vocational programs with a total of 22 individual certifica-

tions. About 2,000 applications are processed annually and currently over 5,500 certificates are held by individuals in California and neighboring states.

### Certification Process

To become certified, *all applicants* must complete the Application for Technical Certification, pay the application fee, have suitable experience and education, and pass the computer-based test. Application instructions and fee schedules are listed on the application. After applications are received at the CWEA office, applicant information is compiled in a database, and reviewed by CWEA staff and Subject Matter experts for the respective vocation applied for. If approved, the applicant will receive an eligibility letter. If the application is rejected, the applicant will be notified and asked to supply more information if warranted.

After completion of the computer-based test and grading, applicants are mailed their official results. Those who pass the exam are mailed certificates and wallet cards.

### Test Administration

#### Test Dates and Sites

Tests are given throughout the year in California, Michigan, and Alaska (see Application for Technical Certification for test schedule). Applicants who are eligible to test will be mailed an acceptance letter and instructions on how to schedule their exam.

#### Test Site Admission

Certificate candidates are required to show at least one valid government-issued photo identification (state driver's license or identification, or passport). Only after positive identification has been made by the testing proctor may a candidate begin the exam. Candidates do not require to show their eligibility letters to enter the test site.



## Section 2: Certification Program Information and Policies

### Test Security

All tests are computer-based. No reference material, laptop computers, or cameras are allowed in the test site. Candidates will have access to an onscreen calculator, however, candidates are welcome to bring their own pre-approved calculator (visit [www.cwea.org/cert](http://www.cwea.org/cert)). Candidates are not allowed to take any notes from the test site. Candidates who violate test site rules may be asked to leave the site and may be disqualified from that test. All violations of test security will be investigated by CWEA and appropriate action will be taken.

### Test Reschedule and Cancellation

To reschedule your application you must submit a written request (a letter stating that you wish to postpone), to postpone to the adjacent testing window. You may only reschedule your application once without a fee. Additional postponement will require a \$40 reschedule fee. There are no exceptions to this policy. If you have a scheduled exam with our testing administrator, Pearson Vue, you must contact them 24 hours in advance to avoid losing your exam fee.

To cancel your application you must submit a written request (a letter stating you wish to cancel your application) to CWEA. The written request must be received at the CWEA office no later than two (2) weeks after the approved testing window. Full refunds, less the \$40 administrative fee, will be made within 4 weeks after the scheduled test date. There are no exceptions to this policy.

### Test Result Notification

Test results are routinely mailed to certificate candidates approximately two weeks after the test date. Results are never given over the phone. All results are confidential and are only released to

the certificate candidate. There are no exceptions to this policy.

### Issue of Certificate/Wallet Card

Certificates and wallet cards are issued to all candidates who pass the test. Certificates and wallet cards are mailed about two to three weeks after result notifications are mailed.

### Certificate Renewal

All certificates are renewed annually. The first renewal is due one year from the last day of the month in which the certification test was held. Certificate renewals less than one year past due are subject to the renewal fee plus a penalty fee of 100 percent of the renewal fee. Certificate holders more than one year past due will need to re-test to regain certification. Renewal notices are mailed to certificate holders two months before the due date. It is the responsibility of certificate holders to ensure the certificate(s) remains valid.

### Accommodations for Physical or Learning Disabilities

In compliance with the Americans with Disabilities Act, special accommodations will be provided for those individuals who provide CWEA with a physician's certificate, or its equivalent, documenting a physical or psychological disability that may affect an individual's ability to successfully complete the certification test. Written requests for special accommodations must be made with the test application along with all supporting documents of disability.

### Test Design and Format

#### Test Design

All certification tests are designed to test knowledge and abilities required to perform the *Essential Duties* listed at the end of this section with minimal acceptable competence.



## Section 2: Certification Program Information and Policies

The *Essential Duties* and Test Content Areas for each certification were determined by a job analysis and meta-analysis of job specifications by two independent psychometric consulting firms. The studies gathered data from onsite visits of over 31 water and wastewater agencies, interviews with 110 water and wastewater professionals, and analysis of more than 300 job specifications. All research was conducted under the guidance of the TCP Committee, vocational sub-committees, and CWEA staff. All test questions are designed to measure at least one area of knowledge or ability that is required to perform an essential duty.

### Test Delivery Mechanism

All tests are computer-based format and are written in the English language only.

### Test Format

All TCP tests are in multiple choice format (see the sample test questions in this guide for an example). The multiple choice format is considered the most effective for use in standardized tests. This objective format allows a greater content coverage for a given amount of testing time and improves competency measurement reliability. Multiple choice questions range in complexity from simple recall of knowledge to the synthesis and evaluation of the subject matter.

### Test Pass Point

The basic minimum score required to pass all tests is 75 percent of possible total points. However, the score may be adjusted downward depending on test complexity. It should be assumed that the passing score is 75 percent and candidates should try to score as high as possible on the test (in other words, always try for 100 percent). The pass point for each vocation and grade level is set independently. Also, each version or form of a test will have its own pass point. Different versions are given each time the certification test is administered.

### How Pass Points Are Set

A modified *Angoff Method* is used to determine the pass point for each version of each test. The modified *Angoff Method* uses expert judgments

to determine the test difficulty. The easier the test, the higher the pass point; similarly the more difficult the test, the lower the pass point.

The following is an outline of the modified *Angoff Method* (some details have been omitted):

1. A group of Subject Matter Experts (SMEs) independently rates each test question within a given test. The ratings are defined as the probability that an acceptably (minimally) competent person with the requisite education and experience will answer the question correctly. An acceptably (minimally) competent person is defined as someone who safely and adequately performs all job functions and requires no further training to do so.
2. The SMEs review each test question as a group. A consensus is reached for the rating of each test question. The SMEs also review comments submitted in writing by test-takers. Any test question that is judged to be ambiguous, has more than one correct answer, or has no correct answers is eliminated from the scoring process for that test. These test questions are then revised for future use, reclassified, or deleted from the test item bank.
3. After the data are refined, the final step is to calculate the mean, or average, of all the test question ratings. This becomes the overall pass point estimation.

### Why Use Modified Angoff?

Each version of a given certification test uses questions from a test item bank. Each of these questions vary in difficulty. Because a different mix of questions is used in each test, the overall difficulty level is not fixed. Thus, it is important to make sure that the varying difficulty level is reflected in the pass point of each test to ensure that test results are reliable. Test reliability is concerned with the reproducibility of results for each version of a given test. In other words, for a test to be reliable it must yield the same result (pass or fail) for the same individual under very similar circumstances. For example, imagine taking a certain grade level test and passing it. Immediately after completing this test, a different version of the same grade level test is taken. If the test is reliable, the same result will be achieved: pass. If a passing grade is not achieved, it is likely that the test is not a reliable measure of acceptable (minimal) competency.



## Section 2: Certification Program Information and Policies

By taking into consideration the difficulty of the test, the modified *Angoff Method* significantly increases the reliability of the test. Also, since each test is adjusted for difficulty level, each test version has the same standard for passing. Thus, test-takers are treated equitably and fairly, even if a different version of the test is taken.

There are other methods for setting pass points. However, for the type of tests administered by CWEA, the modified *Angoff Method* is the best and most widely used.

### Test Scoring

All tests are electronically scored by CWEA. Most test items are valued at one point. Some test items requiring calculations are worth multiple points varying from two to five (possibly more). After tests are scored, total points are compiled and an overall score is calculated as the sum of all points earned on the test. If the overall score is equal to or greater than the established pass point, the candidate has passed the test. Total points possible for each test vary, but the average is 100 points plus or minus 25.

### Item Appeals

Candidates who wish to appeal a specific test item must do so by completing the Candidate Feedback review screen at the end of the exam. Candidate feedbacks will be evaluated and appropriate adjustments will be made to the test content. Candidates submitting feedback will not be contacted in regards to the appeal.

### Qualifying for the Test

Grade I Plant Maintenance Technologist certification is designed to demonstrate competency at the entry level. More specifically, Grade I certification implies competence in the knowledge, skills, and abilities required to perform the *Essential Duties* of an entry level Plant Maintenance Technologist.

Specific experience and educational background for Grade I Plant Maintenance Technologist certification is not required. Completing the Application for Technical Certification and paying the appropriate application fee are the only requirements to qualify for the test. However, it is *recommended* that Grade I candidates have at least one year of

plant maintenance experience performing the *Essential Duties* listed below. Many candidates without such experience have difficulty successfully completing the written test.

### Essential Duties

Grade I Plant Maintenance Technologist essential duties include:

- Interprets and works from basic drawings, designs, schematics, sketches, and written and verbal instructions; performs basic maintenance, repairs, fabrication, and rebuilding of shop, field, and plant equipment used in wastewater treatment plants, pump stations, and collection systems.
- Lubricates, adjusts, and maintains shop, field, and plant equipment, including inspection, cleaning, and repairing wet wells, pipelines, pumps, compressors, valves, chemical feeds, and processing equipment.
- Performs basic preventive and corrective maintenance by isolating power, grounding wires, troubleshooting problems, making repairs, restoring power, and checking for proper operation.
- Performs basic electrical and instrumentation work for additions or modifications by bending and installing conduit, pulling wire, wiring-in circuits as shown on blueprints, and testing systems for proper installation.
- Assists in the installation of, inspection, and repair of a variety of pumps (such as centrifugal, positive displacement, and screw), including servicing, lubricating, adjusting, and maintaining pumps, as well as removing and installing packing and most seals.
- Uses basic welding skills to perform horizontal welding and fabrications with acetylene and arc welders; heating and cutting materials; and fabricating simple projects.
- Maintains, installs, inspects, and repairs piping systems of galvanized, PVC, stainless steel, and copper tubing, including identifying types of piping, fittings, and basic valves, as well as cutting and threading pipes and making minor modifications to existing piping systems.



## Section 2: Certification Program Information and Policies

- Performs basic to routine maintenance and repair tasks on engines, such as changing oil, belts, and spark plugs; replacing filters; obtaining oil and fuel samples; and taking hydrometer readings of coolant and battery fluids.
- Performs regularly scheduled maintenance, inspection, and repair tasks on comminuting and grinding devices; replaces and adjusts cutters and combs; cleans bar screens; lubricates devices; and assists others in more complex repairs.
- Performs basic maintenance, inspection, and repair tasks on mechanical and electrical drive components.
- Maintains, inspects, and repairs a variety of hydraulic, pneumatic and electrical process control equipment.
- Follows safe and proper use of various hand tools, power tools, and test instruments.
- Follows proper safety practices, precautions, and procedures, such as confined-space entry; storing, handling, and transporting gases; using correct Lockout/Tagout procedures; and assisting in rigging, as required, for moving or placing of heavy machinery or equipment.
- Completes minimal work process documentation.



# S e c t i o n 3

## Skill Sets

This section describes the four practical skill sets that candidates should possess to pass the Grade I test. These include safety; tools and equipment; maintenance, repairs, and inspection; and communication and interpersonal relations. The first three skill sets have subsections to further delineate skills.

Table 3-1, presented at the end of this section, cross-references each skill set with a specific chapter, section, and/or page of applicable references to assist the candidate in better understanding the subject matter.

Skill Set	<b>1</b>	Safety
-----------	----------	--------

The certification test covers specific safety precautions regarding Technologists' activities in the plant maintenance field. To achieve certification, candidates must demonstrate the ability to recognize and identify hazards and hazardous situations typically encountered above and below ground in plant maintenance. A fundamental knowledge and appreciation of safety procedures and prevention techniques is required.

### 1.1 General

It is necessary to be familiar with safety laws, rules, and regulations as they apply to maintenance personnel, co-workers, and the public. An understanding of the worker right-to-know law is also important.

Technologists need to know the fundamental techniques used in protecting their own health and the health of those around them. This includes items such as: lifting and back safety; ergonomics; noise hazards; site and facility housekeeping; working with heights, ladders and scaffolds safely; and traffic safety.

### 1.2 Confined Space

It is important to understand what a confined space is and to know if a confined space is "permit required" or not. A general knowledge of the confined-space permit process, entry procedures, and rescue operations is useful.

Understanding confined-space safety rules, requirements, and regulations, as well as accident/injury prevention techniques, is also important. It is necessary to be aware of the hazards and effects of working in confined spaces and what is required in such situations. Technologists need to recognize confined-space safety equipment and understand the function and operation of the various components.

### 1.3 Chemical and Biological Hazards

Numerous chemical and biological hazards associated with plant maintenance may be encountered daily. A basic knowledge of such substances and recognition of their potential for hazard is essential. Technologists should be aware of the policies and procedures for prevention of and protection from these hazards. They should be able to identify the different types of personal protection equipment (PPE), understand how to use PPE properly, and have a basic understanding of what is required, depending upon the work being accomplished and the hazards.

### 1.4 Material Safety Data Sheets (MSDS)

Any hazardous chemical product used within the plant maintenance field has an MSDS. These sheets provide valuable information regarding potentially hazardous chemicals used on the job. Technologists should know what an MSDS is and understand its use.



## Section 3: Skill Sets

### 1.5 Tool and Equipment Safety

Technologists must know the safety hazards associated with the basic hand and power tools used in plant maintenance. Technologists are expected to know when a tool is being used incorrectly, how to identify a defective tool, when the wrong tool is being used for a job, and how to identify an improperly maintained tool or incorrect body positioning when using such a tool.

### 1.6 Machinery Safety

Technologists must know the safety hazards and precautions associated with working around and with machinery. Being aware of the policies and procedures for prevention of and protection from these hazards is also necessary.

Technologists should have knowledge of the safety items associated with machinery, why such items exist, and their proper use. Examples include: safety guards, interlocking guards, controls, feeding and extracting tools, Lockout/Tagout (LO/TO) procedures, automatic starting equipment precautions, and rotating equipment precautions.

### 1.7 Other

It is necessary that all personnel working in plant maintenance have a sound understanding of LO/TO procedures. Technologists should comprehend the policies and procedures set forth by the California Occupational Safety Health Administration (OSHA). A general understanding of written requirements, application rules and regulations, removal requirements, and LO/TO terminology is required.

Use and maintenance of PPE is very important. Safety gloves, Nomex® overalls, face shields, and test equipment should be well maintained, tested, and cleaned in accordance with required standards.

Candidates must be familiar with proper electrical safety procedures, grounding procedures, Lockout/Tagout safety procedures, confined-space entry procedures; Material Data Safety Sheets, OSHA's safety regulations on all electrical PPE testing, chlorine safety procedures, chemical safety procedures, and traffic control safety procedures. Technologists will also benefit from first aid and CPR training.

Technologists should have a basic understanding of fire safety, including how fires start and spread, and how they are put out. Technologists need to be aware of and be able to recognize and properly

report fire hazard conditions that are commonly found in wastewater treatment and collection systems. They should know the four classes of fires and which types of fire-fighting materials and actions are appropriate for each class.

Skill Set	<b>2</b>	Tools and Equipment
-----------	----------	---------------------

The Grade I certification test covers candidates' knowledge of methods, practices, procedures, and tools used in the plant maintenance field.

### 2.1 Hand Tools and Equipment

Technologists should be able to correctly identify the various hand tools and small test equipment used in plant maintenance. It is important to understand the characteristics and operation of tools and equipment as they apply to the plant maintenance field. Technologists should be able to identify various tool parts and testing equipment used in plant maintenance, and must have the ability to recognize and understand the inherent hazards, know when to exercise caution, and know the proper use of these tools and instruments.

Technologists should be familiar with the following tools:

Measuring—tape measures, steel rules, calipers, vernier calipers, micrometers, thread gauges, and squares.

Pipefitting—pipe wrenches, saws, strap and chain wrenches, pipe vises, pipe cutters, tap and die sets, reamers, and tube flaring tools.

Plumbing—propane torches, tube benders, and cast iron pipe snapper and line clearing tools.

Electrical—conduit benders, knockout punches, fish tape, various special pliers, circuit testers, meggers, multi-meters, and amp meters.

Woodworking—saws, planes, scrapers, bits, chisels, levels, plumb bobs, hammers, and nails.

Metalworking—layout tools, rivets and riveting tools, metal-cutting chisels, hammers, metal-cutting snips, notchers, forming tools, hacksaws, vises, files, tap and die sets, and reamers.

Hoisting/Pulling—rope, wire rope, slings, sling hitches, block and tackle, chain falls and machine part pullers.



## 2.2 Power Tools and Instruments

It is important to correctly identify the various power tools and instruments used in plant maintenance and know how to properly operate them. Technologists should have a sound understanding of the characteristics and proper applications of the various power tools and instruments used in the plant maintenance field. They should also have the ability to recognize and understand the inherent hazards, know when to exercise caution, and know the proper use of such tools.

Some power tools (both electric and pneumatic) and instruments that Technologists need to be familiar with include: drills, saws, hammers, screwdrivers, nut-runners, wrenches, routers, planes, sanders, grinders, shears, and concrete cutting and coring devices.

## 2.3 Heavy Equipment and Vehicles

Technologists should be able to correctly identify the various types of heavy equipment commonly used in plant maintenance and have a general understanding of the unique function and application of heavy equipment. An awareness of the hazards associated with heavy equipment operation is also important.

It is important for Technologists to correctly identify and properly operate the various plant maintenance vehicles. Technologists should understand the characteristics and functions of all vehicles used in the plant maintenance field.

<b>Skill Set</b>	<b>3</b>	<b>Maintenance, Repair, and Inspection</b>
------------------	----------	--

The Grade I certification test covers candidates' general knowledge of equipment repair and maintenance techniques in the following areas.

### 3.1 Maintenance Fundamentals

Technologists should understand the principles and purposes of the equipment found in a wastewater treatment plant and collection system. The ability to understand the basic characteristics, electrical theory, and mechanical theory associated with such equipment is also needed.

Technologists should be able to perform basic equipment maintenance and repair, including equipment installation, lubrication, adjustments,

and preventive and proactive maintenance. They must possess a working knowledge of bearings, mechanical power transmission, fasteners, packing and seals, lubrication, piping systems, tubing, alignment, gears, pumps, blowers, fans, screens, boilers, HVAC units, engines, motors, and electrical, instrumentation, and control systems.

### 3.2 Drawings and Prints

Technologists should be able to read, understand, interpret, and work from mechanical drawings, plans, specifications, sketches, and blueprints. They should also be able to identify the basic schematic symbols, abbreviations, and terminology used in prints and drawings. Candidates should understand the differences between and know when to use various types of drawings and prints, including single line, double line, isometric, and orthographic.

### 3.3 Shop Math

It is important for Technologists to be able to do the basic shop math needed in performing plant maintenance duties. Technologists should be familiar with the principles and basic formulas associated with mechanical and electrical maintenance, including unit conversion, percentages, Ohm's Law, power formulas, linear calculations, area, volume, and basic geometry.

### 3.4 Metalworking

Technologists should possess the elemental knowledge and skills needed to fabricate items out of metal and work on metal items associated with plant maintenance. Technologists need to have a basic working knowledge of the four common welding processes. They should also understand the principals of tools used on and how to work with structural steel and sheet metal.

### 3.5 Troubleshooting

It is important for Technologists to be able to diagnose the root cause of common problems associated with plant maintenance equipment. Some of the troubleshooting techniques candidates should be able to use include: reading wear patterns on bearings, reading the effects of pressures and temperature on equipment, reading the faces of mechanical seals, and understanding how to use such information on a pump curve.



### Section 3: Skill Sets

Skill Set	<b>4</b>	<b>Communications and Interpersonal Relations</b>
-----------	----------	---

Grade I certification also addresses whether candidates are able to establish and maintain effective working relationships by communicating, both orally and in writing, clearly and concisely in the English language.

It is important for Technologists to maintain effective communication with customers, co-workers, and supervisors. The ability to follow written and verbal instructions from supervisors is also necessary. Technologists should know when to provide answers to questions and when to refer certain questions to a supervisor instead. They must be able to read, speak, and write in English at a high school education level.

Technologists should be able to establish and maintain effective working relationships with the various personnel with whom they are required to interact. This includes knowledge of and ability to use the common courtesies associated with interpersonal workplace relations.



Table 3-1 Grade I Plant Maintenance Technologist						
Primary References <sup>a</sup>						
No.	Skill Set	Audel Mechanical Trades Pocket Manual 3rd Edition	Basic Math Concepts	Industrial Safety and Health Book 109.1	Using Hand Tools Book 107	Confined Space Entry 1998 Edition
<b>1</b>	<b>Safety</b>					
1.1	General			Lessons 2, 3, 6, 11, 12		
1.2	Confined Space					Entire Book
1.3	Chemical & Biological Hazards			Lesson 4		
1.4	MSDS			Lesson 1		
1.5	Tool and Equipment Safety	Pgs. 186–216		Lessons 3, 5		
1.6	Machinery Safety	Pgs. 227–243		Lesson 7		
1.7a	LO/TO			Lesson 3		
1.7b	Electrical Safety			Lessons 8, 9		
1.7c	Fire Safety	Chapter 21	Lessons 1, 2, 4	Lesson 10		
<b>2</b>	<b>Tools and Equipment</b>					
2.1	Hand Tools & Test Equipment				Entire Book	
2.2	Power Tools & Instruments	Pgs. 186–217				

a. Complete reference information given in Section 6.



### Section 3: Skill Sets

Table 3-1 Grade I Plant Maintenance Technologist						
Primary References <sup>a</sup>						
No.	Skill Set	Audel Mechanical Trades Pocket Manual 3rd Edition	Basic Math Concepts	Industrial Safety and Health Book 109.1	Using Hand Tools Book 107	Confined Space Entry 1998 Edition
<b>3</b>	<b>Maintenance, Repair, and Inspection</b>					
3.1a	Bearings	Pgs. 145–165				
3.1b	Mechanical Power Transmission	Pgs. 46–90				
3.1c	Alignment	Pgs. 90–99				
3.1d	Fasteners	Pgs. 100–119				
3.1e	Pumps	Pgs. 165–169				
3.1f	Packing/ Seals	Pgs. 119–145				
3.1g	Electrical Systems	Pgs. 300–311				
3.2	Drawings & Prints	Pgs. 9–31				
3.3	Shop Math	Pgs. 311–322	Entire Book			
3.4a	Welding	Pgs. 217–227				
3.4b	Structural Steel	Pgs. 169–182				

a. Complete reference information given in Section 6.



# S e c t i o n 4

## Test Preparation

This section provides tips on the how candidates should prepare for the test, information on the test question format and the math skills likely to be needed, and a table of equivalents and formulas.

### Basic Study Strategy

To prepare adequately for the test, candidates need to employ discipline and develop good study habits. Ample time to prepare for the test should be allowed. Candidates should establish a study schedule and stick to it. One or two nights a week for one or two months should be sufficient in most cases. Spend one or more hours studying in quiet surroundings or in small groups of two or three serious candidates. Efforts should be directed to the test subject areas that are not being performed on a day-to-day basis.

It is especially important for candidates to obtain access to the reference materials listed under the Primary References heading in Section 6 of this study guide. Many of these materials are likely to be available in the work place and in technical libraries. Some references, such as codes and regulations, are available on-line as well. For a list of links to on-line resources, see the Certification Resource Links page on the CWEA website at [www.cwea.org/tcp/resources](http://www.cwea.org/tcp/resources).

Candidates should study at the certification level being sought after. There is no advantage to spending time studying material that will not be on the test. Refer to Section 3 of this study guide for topics that will be covered.

While using this study guide, be sure to understand the answers to all the sample and diagnostic test questions. It may also be helpful to use the skill set descriptions in Section 3 to devise additional questions for further study. Discuss the questions with others. Not only is this a good study technique, it is also an excellent way to learn.

It is not necessary, but it can certainly be helpful, to memorize all the formulas and equivalents used in working out the solutions for questions involv-

ing calculations. Table 4-1 lists many, but not all, of these formulas and conversion factors. When the test is administered, a sheet listing some, but not all, of the relevant formulas and equivalents will be provided as part of the test materials. So that candidates may determine which formulas and equivalents will actually be on the sheet included with the test booklet, copies of these sheets are provided on the CWEA website at [www.cwea.org/tcp/resources](http://www.cwea.org/tcp/resources). (The set of equivalents and formulas on the sheet provided with the test may not be exactly the same as the set included in Table 4-1.)

### Multiple Choice Questions

All test questions are written in multiple-choice format. At first glance, the multiple-choice problem may seem easy to solve because so much information is given, but that is where the problem lies. The best answer must be chosen from the information provided. Here are some tips that may help solve multiple-choice problems.

1. Read the question completely and closely to determine what is being asked.
2. Read all the choices before selecting an answer.
3. Look for key words or phrases that often, but not always, tip off correct or incorrect answers:

#### Absolute Words

(Suspect as a wrong choice)

Always	Never	None
Totally	All	

#### Limiting Words

(Often a correct choice)

Few	Occasionally
Some	Generally
Often	Usually
Many	Possible



## Section 4: Test Preparation

Table 4-1 Plant Maintenance Technologist

### Equivalents and Formulas

1 cubic foot = 1,728 cubic inches

1 cubic foot of water = 7.48 gallons

1 cubic foot of water weighs 62.43 pounds

1 gallon of water weighs 8.34 pounds

1 day = 1,440 minutes

1 cubic foot/second = 449 gallons/minute

1 MGD = 694 gallons/minute

1 MGD = 1.55 cubic feet/second

1 psi = 2.31 feet of water

1 horsepower = 746 watts

1 horsepower = 42.45 BTU/minute

1 horsepower = 33,000 foot-pounds/minute

Coefficients of thermal expansion

= 0.00000633/°F for steel

= 0.00001/°F for brass

1 BTU = 778 foot-pounds

1 watt = 3.412 BTU/hour

1 kilowatt = 1000 watts

1 therm = 100,000 BTU

$\pi = 3.14$

Water horsepower =  $\frac{\text{flow} \times \text{total head} \times \text{specific gravity}}{3960}$

Brake horsepower =  $\frac{\text{flow} \times \text{total head} \times \text{specific gravity}}{3960 \times \text{efficiency}}$

Hydrostatic force = column area x column height x fluid density

Thermal expansion = coefficient of thermal expansion x length x  $\Delta T$

Flowing quantity = area x velocity

Power costs =  $\frac{(\text{quantity} \times \text{watts} \times \text{hours})}{1000 \text{ watts/kilowatt}} \times \text{cost/kilowatt} \times \text{time}$

Perimeter

rectangle = 2 x (length + width)

Circumference

circle =  $\pi$  x diameter

Area

rectangle = base x height

triangle =  $\frac{1}{2}$  (base x height)

circle =  $\pi$  x radius<sup>2</sup>

circle = 0.785 x diameter<sup>2</sup>

Volume

rectangular solid = length x width x height

triangular solid =  $\frac{1}{2}$  (base x height x length)

cylinder =  $\pi$  x radius<sup>2</sup> x height

cylinder = 0.785 x diameter<sup>2</sup> x height

$\frac{\text{Big}}{\text{Little}} = \frac{\text{Fast}}{\text{Slow}}$

Energy = power x time

Efficiency =  $\frac{\text{work output}}{\text{work input}}$



- Never make a choice based on the frequency of previous answers. If the last ten questions have not had a “b” answer, don’t arbitrarily select “b”. Instead use logic and reasoning to increase the chances of choosing the best answer.
- Reject answers that are obviously incorrect and choose from the remaining answers.

### Example

The straight line distance from the center of a circle to the outer edge is called the:

- diameter
- circumference
- chord
- radius

It is possible to reason out the answer by having some knowledge of geometry and studying the questions and the four provided answers. The question is asking for the name of a line or distance that is inside of the circle. Circumference is the distance around the outside of the circle, so this is an obvious incorrect answer.

- Make an educated guess.  
Never reconsider a choice that has already been eliminated. This means that answer “b” should not be considered. Look for key phrases or words that give a clue to the right answer. Chord, answer “c,” chord refers to a straight line inside of the circle, but it does not necessarily go through the center of the circle, so this answer can be eliminated.  
Answers “a” and “d” are distances that are measured as straight lines and either start or go through the center of a circle. The diameter goes through the center rather than starting from the center. Radius, answer “d” is the correct answer and is defined as the straight line distance from the center to the outer edge of a circle.
- Skip over questions that are troublesome. Mark these questions for later review.
- When finished with the test, return to the questions skipped. Now think! Make inferences. With a little thought and the information given, the correct answer can be reasoned out.

- Under no circumstances leave any question unanswered. There is no penalty for incorrect answers. However, credit is given only for correct answers.

NO ANSWER=WRONG ANSWER

- Keep a steady pace. Check the time periodically.
- Remember to read all questions carefully. They are not intended to be “trick questions”; however, the intent is to test candidates’ knowledge of and ability to understand the written language of this profession.

## Math Problems

Math problems on the certification tests are meant to reflect the type of work encountered in Plant Maintenance Technology. Although there is no specific math section on the test, many questions will require some calculations such as area, volume, ratios, and conversion of units. By far, the greatest number of applicants who fail the certification tests do so by failing to complete the math problems. Completing the math problems will be greatly simplified by using a calculator and the approach suggested in the following paragraphs.

### Calculators

A scientific calculator may be used during the test; however, a four-function (add, subtract, multiply and divide) calculator is adequate for completing any of the certification tests. Additional functions (e.g., square root) are not necessary, but may be helpful in some situations. The most important factor in effectively using a calculator is the candidate’s familiarity with its use prior to the time of the examination. Confidence in the calculator and a full understanding of how to properly operate it are a must. The best way to gain confidence is to obtain the calculator early and use it frequently.

Completing the sample problems in this section as well as the diagnostic test in Section 5 will improve proficiency. Additional use will also help. For example, calculate the gas mileage when filling a vehicle’s tank. Check the sales tax calculation on each purchase. Balance a checkbook, or check a paycheck. The calculator chosen should have large enough keys so that the wrong keys



## Section 4: Test Preparation

are not accidentally punched. Be certain there are new batteries in the calculator, or use a solar powered calculator with battery backup.

### Approach

The solution to any problem requires understanding of the information given, understanding of what is being requested, and proper application of the information, along with the appropriate equations to obtain an answer. Any math problem can be organized as follows:

#### Given or Known

All information provided in the problem statement that will be used to get the correct answer.

#### Find

A description of the answer that is being requested.

#### Sketch

If possible, sketch the situation described in the problem statement showing size and shape (dimensions).

#### Equation

A listing of the equation or equations that will be used to generate the answer.

#### Assumption(s)

Stated assumptions of key information needed to answer a math problem with missing information. This occurs frequently on higher-grade tests.

#### Answer

This is where the answer is clearly identified.

Advantages to using this approach to organize math problems are that it helps to organize thoughts, breaks the problem solution into a series of smaller steps, and reduces chances of making errors.

### Solutions

Solutions to math problems are like driving routes from Los Angeles to San Francisco: there are many different routes that can be taken. Some routes are shorter or less complicated than others. Only certain routes end up in San Francisco.

Solutions to sample problems given in this study guide are the most common solutions. If a different solution arrives at the correct answer, then it can be used as well.

### Equivalents and Formulas

Familiarity with the equivalents (conversion factors) and formulas in Table 4-1 is important. Pay special attention to the units of measure that are used in the formulas. A correct answer will not be obtained unless the correct units of measure are used.

Check the units, arithmetic, and answer so that:

1. the units agree;
2. the answer is the same when the arithmetic is repeated; and
3. the answer is reasonable and makes sense.

### Dimensional Analysis

When setting up an equation to solve a math problem, the trick is to have clearly in mind what units the answer should be in. Once the units have been determined, work backwards using the facts given and the conversion factors known or given. This is known as dimensional analysis, using conversion factors and units to derive the correct answer.

Remember, multiplying conversion factors can be likened to multiplying fractions. The denominator (the number on the bottom of the fraction) and the numerator (the number on the top of the fraction) cancel each other out if they are the same, leaving the units being sought after.

### Example

If a company runs a discharge pump rated at 50 gallons per minute all day, every day for a year, what is the discharge for the year in millions of gallons per year (MGY)?

Given: pump rating =  $50 \frac{\text{gal}}{\text{min}}$

Find: discharge =  $?$  MGY

#### Calculations

Convert gal/min to million gal/yr, convert gallons to million gallons, and minutes to years.

What is known about minutes and years? There are 60 minutes in an hour, 24 hours in a day, and 365 days in a year. Put that into an equation, and multiply each conversion factor so the unneeded units are cancelled out:

$$50 \frac{\text{gal}}{\text{min}} \times 60 \frac{\text{min}}{\text{hr}} \times 24 \frac{\text{hr}}{\text{day}} \times 365 \frac{\text{days}}{\text{yr}} \times \frac{1 \text{ MG}}{1,000,000 \text{ gal}} = 26.28 \text{ MGY}$$



## Sample Questions

The following sample math problems are intended to demonstrate unit conversion techniques. Although they are general wastewater problems, the questions may not be specific to any vocation.

1. How many gallons of water will it take to fill a 3 cubic foot container?

$$3 \text{ cubic feet} \times 7.48 \frac{\text{gallons}}{\text{cubic feet}} = 22.4 \text{ gallons}$$

2. If a gallon of gasoline weighs 7.0 pounds, what would be the weight of a 350 gallon tank full of gasoline?

$$350 \text{ gallons} \times 7.0 \frac{\text{pounds}}{\text{gallon}} = 2,450 \text{ pounds}$$

3. The rated capacity of a pump is 500 gallons per minute (GPM). Convert this capacity to million gallons per day (MGD).

$$500 \text{ GPM} \times 1 \frac{\text{MGD}}{694 \text{ GPM}} = 0.72 \text{ MGD}$$

4. A chemical feed pump is calibrated to deliver 50 gallons per day (GPD). What is the calibrated chemical feed in gallons per minute (GPM)?

$$\frac{50 \text{ gal}}{\text{day}} \times \frac{1 \text{ day}}{24 \text{ hr}} \times \frac{1 \text{ hr}}{60 \text{ min}} = 0.035 \text{ GPM}$$

5. A chemical feed pump delivers 50 mL per minute (mL/min). Determine the chemical feed in gallons per day (gpd).

$$\frac{50 \text{ mL}}{\text{min}} \times \frac{1 \text{ L}}{1000 \text{ mL}} \times \frac{1 \text{ gallon}}{3.785 \text{ L}} \times \frac{60 \text{ min}}{\text{hr}} \times \frac{24 \text{ hr}}{\text{day}} = 19 \text{ GPD}$$

6. A cyanide destruction process is designed to treat 30 pounds of cyanide per 24-hour operational day. How many pounds of cyanide can be treated during an 8-hour shift?

$$\frac{30 \text{ lbs CN}}{\text{day}} \times \frac{8 \text{ hr}}{\text{shift}} \times \frac{1 \text{ day}}{24 \text{ hr}} = 10 \text{ lbs CN/shift}$$

## Math Skills

Grade I Technologists must be skilled in basic arithmetic and geometry. Candidates should be able to apply these skills to calculations for work-related tasks involving excavation, stationing, pumping, determining flow rate, cost estimation, and other job-related activities that fall within the skill set subject areas discussed in Section 3.

A thorough review of the types of mathematics required for the test is beyond the scope of this study guide. Consult an appropriate math text (see Section 6, References) if there is unfamiliarity with any specific math skill. Appendix A provides general strategies for approaching math problems and math anxiety, as well as resources for remedial study. Below are some examples of the types of math problems that a candidate should be able to quickly solve.

## Arithmetic

Candidates should be able to understand and perform the following calculations, either manually or with a calculator:

1. Addition and subtraction of whole numbers, fractions, and decimals.
2. Multiplication and division of whole numbers, fractions, and decimals.

Be prepared to apply such basic skills to work-related problems. The following example problems require application of knowledge, basic arithmetic, and the ability to convert units.

## Example

Determine the volume of a concrete slab that measures 150 feet long, 200 feet wide, and 3 inches thick. Express your answer in cubic yards.

First convert inches to feet:

$$3 \text{ inches} \times \frac{1 \text{ foot}}{12 \text{ inches}} = 0.25 \text{ feet}$$

Next, using the formula for volume given in Table 4-2, determine the volume of the concrete slab in cubic feet:

$$\begin{aligned} \text{Vol} &= \text{length} \times \text{width} \times \text{height} \\ \text{Vol} &= 150 \text{ feet} \times 200 \text{ feet} \times 0.25 \text{ feet} \\ \text{Vol} &= 7,500 \text{ cubic feet} \end{aligned}$$



## Section 4: Test Preparation

Finally, calculate the volume of concrete in cubic yards:

$$\text{Vol} = 7,500 \text{ cubic feet} \times \frac{1 \text{ cubic yard}}{27 \text{ cubic feet}}$$

Volume of concrete = 277.78 cubic yards

### Example

Find the volume of water required to fill a sewer pipe that measures 1,000 feet in length and has a diameter of 12 inches. Express your answer in gallons.

First convert inches to feet:

$$\text{Diameter} = 12 \text{ inches} \times \frac{1 \text{ foot}}{12 \text{ inches}} = 1 \text{ foot}$$

Next calculate the volume:

$$\begin{aligned} \text{Vol} &= 0.785 \times \text{diameter}^2 \times \text{height} \\ &= 0.785 \times 1 \text{ foot} \times 1 \text{ foot} \times 1,000 \text{ feet} \\ &= 785 \text{ cubic feet} \end{aligned}$$

Finally, calculate the volume of water gallons:

$$\text{Vol} = 785 \text{ cubic feet} \times \frac{7.48 \text{ gallons}}{1 \text{ cubic foot}}$$

Volume of water = 5,872 gallons

### Geometry

Candidates should be able to calculate circumference, find the area of a rectangle or circle, and find the volume of a rectangular solid or a right cylinder. The following example problem requires application of knowledge, basic geometry, arithmetic, and the ability to convert units.

### Example

What is the volume of a cylindrical digester 140 feet in diameter and 15 feet tall? Express your answer in million gallons (MG).

First calculate the volume of the digester in cubic feet using the formula given in Table 4-1.

$$\text{Vol} = 0.785 \times \text{diameter}^2 \times \text{height}$$

$$\text{Vol} = 0.785 \times 140 \text{ ft} \times 140 \text{ ft} \times 15 \text{ ft} = 230,790 \text{ ft}^3$$

Converting cubic feet to million gallons:

$$\text{Vol} = 230,790 \text{ ft}^3 \times \frac{7.48 \text{ gal}}{\text{ft}^3} \times \frac{\text{MG}}{1,000,000 \text{ gal}}$$

$$\text{Vol} = 1.726 \text{ MG}$$



# S e c t i o n 5

## Diagnostic Test

### Introduction

This section provides a diagnostic test to assist those studying for the Grade I Plant Maintenance Technologist certification test in evaluating their current knowledge level about safety; tools and equipment; maintenance, repair, construction, and inspection of a wastewater treatment plant and collection systems; and communications and interpersonal relationships.

The example questions in the diagnostic test represent the type of knowledge that may be required to successfully pass the certification test. They are based generally on the information contained in the references listed in Section 6 of this study guide, and they are arranged according to the skill sets presented in Section 3.

However, passing the diagnostic test does not guarantee passing the certification test. Diagnostic test answers, the applicable skill sets, and selected solutions are presented at the end of this section. Candidates should take the diagnostic test, mark wrong answers, and record the skill sets for questions missed. Using Table 3-1, candidates should review the references to improve their knowledge of the subjects, especially in areas where they answered text questions incorrectly.

Skill Set	<b>1</b>	Safety
-----------	----------	--------

1. When conducting a confined space entry, you must test the atmosphere prior to opening, at entry, after opening, and every \_\_\_\_\_ minutes until the confined space entry is ended.
  - a. 30
  - b. 25
  - c. 20
  - d. 15

2. The best place to find out what personal protective gear is necessary when working with a chemical is:
  - a. MSDS.
  - b. container level.
  - c. EPA.
  - d. to consult other workers with previous experience.
3. When rigging a piece of equipment that requires a sling, what type of sling gives the highest safe load rating?
  - a. Choker
  - b. U-sling
  - c. 60-degree
  - d. 45-degree

Skill Set	<b>2</b>	Tools and Equipment
-----------	----------	---------------------

1. When using a micrometer, the part of the micrometer that you grip and turn to adjust the micrometer is called the:
  - a. anvil.
  - b. spindle.
  - c. sleeve.
  - d. thimble.
2. This type of screwdriver is very useful in starting screws in hard-to-reach areas.
  - a. Split-tip
  - b. Ratchet-handle
  - c. Offset
  - d. Electrician's



## Section 5: Diagnostic Test

3. What is the definition of plumb?
  - a. Vertical trueness
  - b. Horizontal trueness
  - c. Vertical paring
  - d. Horizontal paring

Skill Set	<b>3</b>	<b>Maintenance, Repair, and Inspection</b>
-----------	----------	--

1. Which decimal prefix expresses 1/1000?
  - a. Micro
  - b. Milli
  - c. Kilo
  - d. Deka
2. A pump needs to be repacked when:
  - a. no more packing will fit into the stuffing box.
  - b. there is excessive leakage from the packing.
  - c. the packing is more than one year old.
  - d. the packing gland is pulled all the way down and there is excessive leakage.
3. The straight line distance from the center of a circle to the outer edge is called the:
  - a. diameter.
  - b. circumference.
  - c. chord.
  - d. radius.
4. The type of gear referred to as the basic gear, which has straight teeth that are parallel to the bore centerline, is called:
  - a. a bevel gear.
  - b. a single helical gear.
  - c. a herringbone gear.
  - d. a spur gear.
5. When you need to seal the shaft of a pump so that practically no leakage occurs, you would use:
  - a. angle cut packing.
  - b. butt cut packing.
  - c. angle cut packing and a lantern ring.
  - d. a mechanical seal.
6. Ohm's law is:
  - a.  $E = I \times R$
  - b.  $I = E \times R$
  - c.  $P = E \times I$
  - d.  $E = P \times I$
7. A fence is to be installed on the perimeter of a sewer lift station. The sides of the pump station measure 235 feet, 366 feet, 266 feet and 298 feet. If a 20 foot gate is to be installed in the 266 foot section, how many linear feet of fence will be required?
  - a. 1,140 ft
  - b. 1,145 ft
  - c. 1,165 ft
  - d. 1,265 ft
8. A circle has a circumference of 393 feet. What is its diameter?
  - a. 63 ft
  - b. 98 ft
  - c. 125 ft
  - d. 197 ft
9. A circuit has 120 volts applied across a resistance of 6 ohms. What is the current?
  - a. 20 amps
  - b. 50 watts
  - c. 75 watts
  - d. 720 amps



## Section 5: Diagnostic Test

10. A trough is triangular in shape. The triangular cross section measures 3 feet across and 4 feet deep. What is the area of the cross section, in square feet?
- 3.5 ft<sup>2</sup>
  - 6 ft<sup>2</sup>
  - 12 ft<sup>2</sup>
  - 14 ft<sup>2</sup>
11. The training room at your plant needs new carpet. If the room is rectangular in shape and measures 30 feet by 54 feet, how much carpet is needed, in square yards.
- 84 yd<sup>2</sup>
  - 180 yd<sup>2</sup>
  - 540 yd<sup>2</sup>
  - 1,620 yd<sup>2</sup>
12. A 480-volt system has a resistance of 20 ohms. What is the power consumed, in watts?
- 20 watts
  - 24 watts
  - 9,600 watts
  - 11,520 watts
13. A digester has a radius of 75 feet. What is the surface area of the sludge in the digester, in square feet?
- 29 ft<sup>2</sup>
  - 236 ft<sup>2</sup>
  - 17,673 ft<sup>2</sup>
  - 35,325 ft<sup>2</sup>
14. You are required to paint the walls of a room that is 20 feet wide, 30 feet long and 8 feet high. If the paint you are using covers 200 square feet per gallon, how many gallons of paint will you need?
- 2 gal
  - 4 gal
  - 10 gal
  - 20 gal
15. What is the volume of a digester that has a radius of 75 feet and a height of 50 feet, in million gallons (MG)?
- 6.61 MG
  - 28.05 MG
  - 33.03 MG
  - 118.13 MG
16. A wet well measures 30 feet deep, 25 feet wide and 35 feet long. What is its capacity, in gallons?
- 3,509,000 gal
  - 19,635,000 gal
  - 26,250,000 gal
  - 196,350 gal
17. If a digester is 75 feet tall and 150 feet in diameter, what is the volume, in million gallons (MG)?
- 0.26 MG
  - 6.61 MG
  - 9.91 MG
  - 13.25 MG
18. A trench is to be excavated. If the trench is 1,500 feet long and averages 6 feet deep and 3 feet wide, how many cubic yards of material will be removed?
- 270 yd<sup>3</sup>
  - 1,000 yd<sup>3</sup>
  - 7,000 yd<sup>3</sup>
  - 9,000 yd<sup>3</sup>
19. A steel bar is 6.5 inches long. It is heated from 75°F to 250°F. What is the new length of the steel bar? The coefficient of thermal expansion is 0.00000633/°F for steel.
- 6.4928 in
  - 6.5006 in
  - 6.5072 in
  - 6.5720 in



## Section 5: Diagnostic Test

Skill Set	<b>4</b>	Communications and Interpersonal Relations
-----------	----------	--

- Which of the following is considered important when communicating with the public by telephone?
  - Understanding
  - Rudeness
  - Courtesy
  - Decisiveness
- Of the following, which would be most important when communicating with the public in person?
  - Appearance and attitude
  - Disheveled appearance
  - Aggressiveness
  - Answering the question even if you do not know the answer
- If you have been given written instructions that you do not understand:
  - do what you think is best.
  - ask a co-worker.
  - ask your supervisor.
  - ask the author.

## Test Answer Key

Skill Set	<b>1</b>	Safety
-----------	----------	--------

No.	Answer	Skill Set
1	c	1.2
2	a	1.3
3	b	1.5

Skill Set	<b>2</b>	Tools and Equipment
-----------	----------	---------------------

No.	Answer	Skill Set
1	d	2.1
2	a	2.1
3	a	2.1

Skill Set	<b>3</b>	Maintenance, Repair, and Inspection
-----------	----------	-------------------------------------

No.	Answer	Skill Set
1	b	3.3
2	c	3.1
3	d	3.3
4	d	3.1b
5	d	3.1f
6	a	3.1g
7	b	3.2
8	c	3.2
9	a	3.3
10	b	3.2
11	b	3.2
12	d	3.3
13	c	3.3
14	b	3.3
15	a	3.3
16	d	3.3
17	c	3.3
18	b	3.3
19	c	3.4



## Section 5: Diagnostic Test

Skill Set	4	<b>Communications and Interpersonal Relations</b>
-----------	---	---

No.	Answer	Skill Set
1	c	4
2	a	4
3	d	4

### Selected Problem Solutions

Skill Set	3	<b>Maintenance, Repair, and Inspection</b>
-----------	---	--

7. A fence is to be installed on the perimeter of a sewer lift station. The sides of the pump station measure 235 feet, 366 feet, 266 feet and 298 feet. If a 20 foot gate is to be installed in the 266 foot section, how many linear feet of fence will be required?

First draw a picture and label the sides.

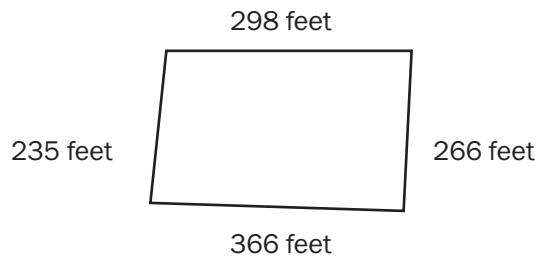

The perimeter of this form is equal to the sum of the sides. The linear feet of fence required is equal to the perimeter minus the width of the gate.

$$\text{Perimeter} = 298 \text{ feet} + 266 \text{ feet} + 366 \text{ feet} + 235 \text{ feet} = 1,165 \text{ feet}$$

$$\text{Feet of fence} = 1,165 \text{ feet} - 20 \text{ feet}$$

$$\text{Feet of fence} = 1,145 \text{ feet}$$

8. A circle has a circumference of 393 feet. What is its diameter?

First draw a picture and label the known values.

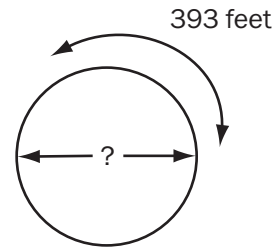

$$\text{Circumference} = \pi \times \text{diameter}$$

$$393 \text{ feet} = 3.14 \times \text{diameter}$$

$$\frac{393 \text{ feet}}{3.14} = \text{diameter} = 125 \text{ feet}$$

9. A circuit has 120 volts applied across a resistance of 6 ohms. What is the current?

$$E = IR \text{ or voltage} = \text{current} \times \text{resistance}$$

$$120 \text{ volts} = \text{current in amps} \times 6 \text{ ohms}$$

$$\frac{120 \text{ volts}}{6 \text{ ohms}} = \text{current in amps} = 20 \text{ amps}$$

10. A trough is triangular in shape. The triangular cross-section measures 3 feet across and 4 feet deep. What is the area of the cross section?

First draw a picture and label the known values.

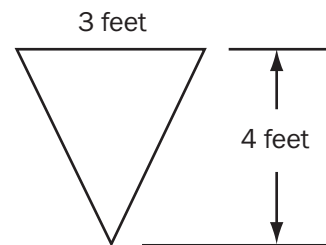

$$\text{Area of a triangle} = \frac{1}{2} (\text{base} \times \text{height})$$

$$\text{Area} = \frac{1}{2} (3 \text{ ft} \times 4 \text{ ft})$$

$$\text{Area} = 6 \text{ ft}^2$$



## Section 5: Diagnostic Test

11. The training room at your plant needs new carpet. If the room is rectangular in shape and measures 30 feet by 54 feet, how much carpet is needed in both square yards?

First draw a picture and label the known values. This is an area problem; the shape is a rectangle.

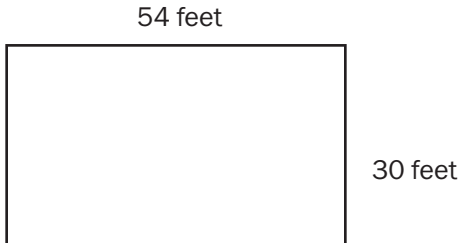

Area of a rectangle = length x width

$$\text{Area} = 54 \text{ ft} \times 30 \text{ ft} = 1,620 \text{ ft}^2$$

$$1 \text{ yd}^2 = 9 \text{ ft}^2$$

$$\text{Area} = 1,620 \text{ ft}^2 \times \frac{1 \text{ yd}^2}{9 \text{ ft}^2} = 180 \text{ yd}^2$$

12. A 480-volt system has a resistance of 20 ohms. What is the power consumed, in watts?

$P = EI$  or power = voltage x current

Since you know the voltage but not the current, you have to calculate current.

$E = IR$  or voltage = current x resistance

$$480 \text{ volts} = \text{current in amps} \times 20 \text{ ohms}$$

$$\frac{480 \text{ volts}}{20 \text{ ohms}} = \text{current in amps} = 24 \text{ amps}$$

$$P = EI$$

$$P = 480 \text{ volts} \times 24 \text{ amps}$$

$$P = 11,520 \text{ watts}$$

13. A digester has a radius of 75 feet. What is the surface area of the sludge in the digester, in square feet?

First draw a picture and label the known values. This is an area problem; the shape is a circle.

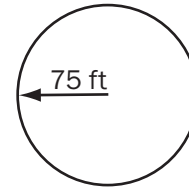

Area of a circle =  $0.785 \times \text{diameter}^2$

$$\text{Diameter} = 2 \times \text{radius} = 2 \times 75 \text{ ft} = 150 \text{ ft}$$

$$\text{Area} = 0.785 \times (150 \text{ ft})^2$$

$$\text{Area} = 0.785 \times (150 \text{ ft} \times 150 \text{ ft})$$

$$\text{Area} = 0.785 \times (22,500 \text{ ft}^2) = 17,673 \text{ ft}^2$$

14. You are required to paint the walls of a room that is 20 feet wide, 30 feet long and 8 feet high. If the paint you are using covers 200 square feet per gallon, how many gallons of paint will you need?

First draw a picture and label the known values. In this case, there are four walls. All are 8 feet high. Two are 20 feet wide and two are 30 feet wide.

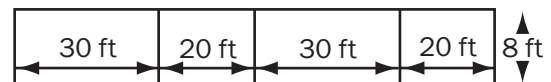

The question is how many gallons will be needed, thus requiring conversion from area (square feet) to gallons. The paint covers 200 square feet per gallon.

Therefore,  $200 \text{ ft}^2 = 1 \text{ gallon}$ .

So, all that is needed is find the total area to be painted and convert from area to gallons.

Area of a wall = width x height

Total area = area wall 1 + area wall 2 + area wall 3 + area wall 4

$$\text{Total area} = (30 \text{ ft} \times 8 \text{ ft}) + (20 \text{ ft} \times 8 \text{ ft}) + (30 \text{ ft} \times 8 \text{ ft}) + (20 \text{ ft} \times 8 \text{ ft}) = 800 \text{ ft}^2$$

$$\text{Gallons needed} = 800 \text{ ft}^2 \times \frac{1 \text{ gal}}{200 \text{ ft}^2} = 4 \text{ gal}$$



## Section 5: Diagnostic Test

15. What is the volume of a digester that has a radius of 75 feet and a height of 50 feet, in million gallons (MG)?

First draw a picture and label the known values. This is a volume problem; the shape is a cylinder.

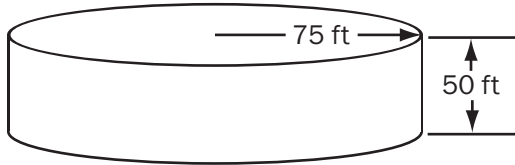

$$7.48 \text{ gallons} = 1 \text{ ft}^3$$

$$1,000,000 \text{ gallons} = 1 \text{ MG}$$

$$\begin{aligned} \text{Volume of a cylinder} \\ = 0.785 \times \text{diameter}^2 \times \text{height} \end{aligned}$$

$$\text{Diameter} = 2 \times \text{radius} = 2 \times 75 \text{ ft} = 150 \text{ ft}$$

$$\text{Vol} = 0.785 \times (150 \text{ ft})^2 \times 50 \text{ ft}$$

$$\text{Vol} = 0.785 \times 22,500 \text{ ft}^2 \times 50 \text{ ft}$$

$$\text{Vol} = 883,125 \text{ ft}^3$$

$$\text{Vol} = 883,125 \text{ ft}^3 \times \frac{7.48 \text{ gal}}{1 \text{ ft}^3} \times \frac{1 \text{ MG}}{1,000,000 \text{ gal}}$$

$$\text{Vol} = 6.61 \text{ MG}$$

16. A wet well measures 30 feet deep, 25 feet wide and 35 feet long. What is its capacity, in gallons?

First draw a picture and label the known values. This is a volume problem; the shape is a rectangular solid.

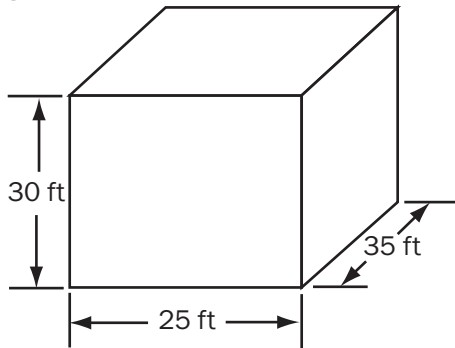

$$\begin{aligned} \text{Volume of rectangular solid} \\ = \text{length} \times \text{width} \times \text{height} \end{aligned}$$

$$7.48 \text{ gallons} = 1 \text{ ft}^3$$

$$\text{Vol} = 35 \text{ ft} \times 25 \text{ ft} \times 30 \text{ ft} = 26,250 \text{ ft}^3$$

$$\text{Vol} = 26,250 \text{ ft}^3 \times \frac{7.48 \text{ gallons}}{1 \text{ ft}^3}$$

$$\text{Vol} = 196,350 \text{ gallons}$$

17. If a digester is 75 feet tall and 150 feet in diameter, what is the volume in million gallons (MG)?

First draw a picture and label the known values. This is a volume problem; the shape is a cylinder.

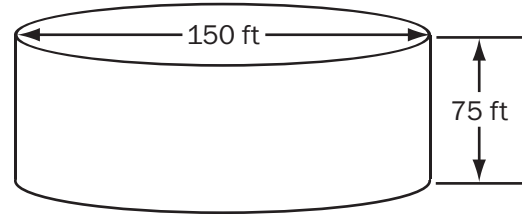

$$7.48 \text{ gallons} = 1 \text{ ft}^3$$

$$1,000,000 \text{ gallons} = 1 \text{ MG}$$

$$\begin{aligned} \text{Volume of a cylinder} \\ = 0.785 \times \text{diameter}^2 \times \text{height} \end{aligned}$$

$$\text{Vol} = 0.785 \times (150 \text{ ft})^2 \times 75 \text{ ft}$$

$$\text{Vol} = 1,324,687.5 \text{ ft}^3$$

$$\text{Vol} = 1,324,687.5 \text{ ft}^3 \times \frac{7.48 \text{ gal}}{1 \text{ ft}^3} \times \frac{1 \text{ MG}}{1,000,000 \text{ gal}}$$

$$\text{Vol} = 9.91 \text{ MG}$$

## Section 5: Diagnostic Test

18. A trench is to be excavated. If the trench is 1,500 feet long and averages 6 feet deep and 3 feet wide, how many cubic yards of material will be removed?

First draw a picture and label the known values. This is a volume problem; the shape is a rectangular solid.

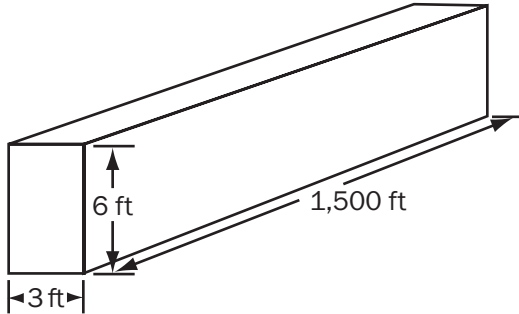

1 cubic yard = 27 cubic feet

Volume of rectangular solid  
= length x width x height

$$\text{Vol} = 1,500 \text{ ft} \times 3 \text{ ft} \times 6 \text{ ft} = 27,000 \text{ ft}^3$$

$$\text{Vol} = 27,000 \text{ ft}^3 \times \frac{1 \text{ cubic yard}}{27 \text{ cubic feet}}$$

$$\text{Vol} = 1,000 \text{ yd}^3$$

19. A steel bar is 6.5 inches long. It is heated from 75°F to 250°F. What is the new length of the bar? The coefficient of thermal expansion is 0.00000633/°F for steel.

The question asks for the new length, which is the amount of expansion plus the original length.

New Length  
= Thermal Expansion + Original Length

Thermal Expansion  
= coefficient of thermal expansion x length x  $\Delta T$

$$\text{Thermal Expansion} = 0.00000633/\text{°F} \times (250\text{°F} - 75\text{°F}) \times 6.5 \text{ in} = 0.0072 \text{ in}$$

$$\text{New Length} = 0.0072 \text{ in} + 6.5 \text{ in}$$

$$\text{New Length} = 6.5072 \text{ in}$$



# S e c t i o n 6

## References

This section provides titles and information on primary and secondary references found useful in obtaining Grade I Plant Maintenance Technologist certification. Because primary references contain most of the information needed for the certification test, it is recommended that candidates obtain access to them for personal use.

Many of these publications may be reviewed and purchased on-line from their publishers or from electronic book retailers. Others may be found in a wastewater treatment plant library or in a college or university library. In addition, see the CWEA Certification Resource Links page at [www.cwea.org/tcp/resources](http://www.cwea.org/tcp/resources) for links to resources available on-line and any updates or changes to the information and URLs listed below.

### Primary References

*Audel Mechanical Trades Pocket Manual*

Carl A. Nelson

ISBN 0025886657

Pub. Date: April 1990

Maintenance Troubleshooting

273 Polly Drummond Rd.

Newark, DE 19711

800/755-7672

[www.mtroubleshooting.com](http://www.mtroubleshooting.com)

catalog # MTM-1025

look under "Mechanical Trades"

*Basic Math Concepts for Water and Wastewater Plant Operators*

Joanne Kirkpatrick Price

ISBN 0877628084

CRC Press

800/272-7737

[www.crcpress.com](http://www.crcpress.com)

*Industrial Safety and Health, Book 109.1*

*Hand Tools, Book 107*

TPC Training Systems

750 Lake Cook Road

Buffalo Grove, IL 60089

800/837-8872, ext. 4060

[www.tpctraining.com](http://www.tpctraining.com)

*Confined Space Entry, 1998 Edition*

Order No: P07115WW

Water Environment Federation

601 Wythe Street

Alexandria, VA 22314-1994

800/666-0206

[www.wef.org](http://www.wef.org)

### Secondary References

The information contained in the Primary References listed above provides a solid base of knowledge for the Technologist. Additional sources of information for Grade I candidates include:

Equipment Operation and Maintenance Manuals

Vendor Repair Manuals

Trade Magazines, paid for

Trade Magazines, free

(e.g., *Maintenance Technology, Plant Services, Pumps and Systems, Reliability Magazine, Valve Magazine*, and *Practicing Oil Analysis*)

Classes and Seminars

Additional recommended books for Technologists include:

*Pump Handbook, 3rd Edition*

Igor Karassik, Joseph Messina, Paul Cooper and Charles Heald

ISBN 0070340323

Pub. Date: September 2000

McGraw-Hill Professional Publishing Group

800/262-4729

[www.books.mcgraw-hill.com](http://www.books.mcgraw-hill.com)



## Section 6: References

### *Piping Handbook, 7th Edition*

Mohinder Nayyar  
ISBN 0070471061  
Pub. Date: October 1999  
McGraw-Hill Professional Publishing Group  
800-262-4729  
www.books.mcgraw-hill.com

### *Centrifugal Pump Sourcebook*

John W. Dufour and W. Ed Nelson  
ISBN 00701803334  
Pub. Date: 1992  
The McGraw-Hill Companies  
(Out of print, but can be found online through  
Amazon or other online booksellers)

### *Pumps and Pumping, 7th Edition*

Skeet Arasmith  
ACR Publications  
1298 Elm Street SW  
Albany, OR 97321  
800/433-8150  
www.acrp.com

### *Supervisor's Guide to Safety and Health Programs*

Water Environment Federation  
601 Wythe Street  
Alexandria, VA 22314  
800/666-0206  
www.wef.org

### *Machinery Failure Analysis and Troubleshooting, Volume 2*

Heinz Bloch  
ISBN: 0884156621  
Gulf Publishing Company  
2 Greenway Plaza, Ste 1020  
Houston, TX 77046  
713/529-4301 Fax: 713/520-4433  
www.gulfpub.com

### *Instrumentation, 3rd Edition*

Franklyn W. Kirk and Nicholas R. Rimboi  
ISBN 0826934226  
Pub. Date: January 1975  
American Technical Publishers, Incorporated  
1155 West 175th Street  
Homewood, IL 60430-4600  
800-323-3471  
www.go2atp.com

### *NFPA 70B: Recommended Practice for Electrical Equipment Maintenance, 1998 Edition*

National Fire Protection Association  
11 Tracy Drive  
Avon, MA 02322  
800/344-3555  
www.nfpa.org

### *Process/Industrial Instruments and Controls Handbook, 5th Edition*

Gregory K. McMillan (Editor) and Douglas M. Considine  
ISBN 0070125821  
Pub. Date: October 1999  
McGraw-Hill Professional Publishing Group  
800-262-4729  
www.books.mcgraw-hill.com

### *Math Text for Water and Wastewater Technology, 2nd Edition*

Wright's Training  
P. O. Box 515  
Elmira, CA 92625  
707/448-3659  
Download form to order: www.wrights-  
trainingsite.com

### *Applied Math for Wastewater Plant Operators*

Joanne Kirkpatrick Price  
ISBN 0877628092  
CRC Press  
800-272-7737  
www.crcpress.com



## You and Wastewater Math

by Cheryl Ooten, Mathematics Professor, Santa Ana College, [Ooten\\_Cheryl@rscsd.org](mailto:Ooten_Cheryl@rscsd.org)

Example math problems found in Appendix A are representative of general wastewater math and are designed to illustrate a math problem solving strategy, not specific math skills. Examples given in this appendix may not be like the problems given on the test for your discipline. However, the problems are typical of types of problems you may encounter, including, but not limited to, basic algebra (solving one equation for one unknown), story problems, and plane and solid geometry (area and volume problems). For specific kinds of math skills and problems you may encounter on the Grade III Plant Maintenance Technologist certification test, please review Sections 3, 4, and 5 of this study guide.

### Introduction

Now is the time for you to begin preparation for the math portion of your technical certification exam. This Appendix provides suggestions to take charge of:

- Your math skills
- Your attitudes toward math
- Your test-taking skills

By doing this, you can improve your performance in successfully completing the math questions on the certification exam.

### Two Facts to Consider

First, since early childhood, you have used math mostly without giving it a second thought. Knowing your age, counting, comparing sizes and shapes, adding your money, and subtracting to get change are math skills.

You drive the streets judging distances, speeds, and times. You estimate if you can afford a vacation or a car and when you can retire. You compare volumes and areas as you build and do jobs around the work site. You even measure volume

in putting toothpaste on your toothbrush. You use statistics as you watch sports and consider things like RBIs in baseball or field goal percentages in basketball. All of these are mathematical skills many people take for granted.

Second, if you think math is hard, please know that math becomes hard for *everyone* at some point. You are not alone. There are math problems that have been unsolved for hundreds of years even though they have been attempted by competent, well-informed mathematicians who may work at them for decades. Those are not the problems you need to work unless you are curious. When you work at your appropriate level, you find a combination of easy ideas and hard ideas.

You may get discouraged comparing your speed and understanding in math with others. Those people who appear to do math easily have, most likely, done those specific problems, or ones like them, many, many times.

You will want to study and progress at your “growing edge”—the skill level where you have a bit of discomfort with new material, but where you are not totally overwhelmed. You can expect challenges that trouble you, but that can be overcome. Instead of saying “I cannot do math,” decide now to begin learning enough math to make work and test-taking easier.

### Move Beyond the Math You Know

To move beyond your routine skill level in math, consider the following points:

#### **You Have Skills.**

You already have many math skills and can build on that base. It is best and easiest to build on what you already know.

#### **Basics are Important.**

Going back over the basics of what you know will build confidence and help you progress and add new math skills to your ability to solve math problems.



## Appendix A: You and Wastewater Math

### **Math Progresses Logically.**

There are many different areas of math and each builds on itself as well as on the others. If you cannot do a particular problem, it may be because you have missed something basic to that one area along the way. Working your way up slowly and cumulatively in math is the fastest way to gain skills.

### **Words Count.**

Each and every word and symbol in math means something. You need to find out those meanings and then practice them. If you do not know what “mgd” or “psi” means, or which units measure “flow”, it is harder to do problems involving them. It can seem like a foreign language.

### **Brains are Unique.**

Each individual brain is wired differently, causing each person to think and learn differently. The more you know about the way you as a specific individual learn, the more you will permit yourself to do what it takes to learn math. Some people need to do many written repetitions. Some need to walk or move around as they do math. Some need to talk out loud. Others need to draw pictures. Some need to work problems with other people. Some need to use words and some need to use symbols. In order to focus on how to move forward, think about what works for you or where learning has been difficult for you.

If you are an independent learner, you might find a basic math book at your library to work through on your own. You may be able to study with your own children to learn some math together or with your friends and colleagues. You may have an old math book you used a long time ago that could be helpful, and you may come to remember what you learned from it.

### **Assessment Helps.**

Assess your skill level honestly. Math placement tests are available at your local college and through private educational agencies to help you determine where your skills are and where you can best get help to make comfortable progress.

### **You are Not Alone.**

No one promises that math will always be easy or interesting for you. For most people, working on math is a challenge. Persevering and pushing personal limits allows you to experience the satisfaction of success.

Get help when you get discouraged or experience confusion. Remember this is just a momentary problem in a sequence of ideas that you are confronting. Do not buy into the myth that you have to do math alone. Do not believe it is demeaning for you to admit you do not understand. You can have fun if you lighten up as you progress. Working with others is an outstanding way to improve math skills.

### **Questions are Essential.**

Make a list of people with whom you feel comfortable discussing your math questions. They may be your colleagues, teachers, fellow students, friends, or family members—even your children. Do not ask just anybody; pick people who are helpful and positive or non-judgmental about your questions.

### **Mistakes Happen.**

Expect mistakes up front. As you learn anything new, you will make errors. Do not blame your mistakes on math itself! In any new endeavor you need to allow yourself to crawl before you can walk. Successful people in all fields know this. Trial and error is the basis of all learning.

You can learn more from your mistakes than from repeated successes. Making errors gives you feedback by showing you what you do not understand. Learn to value and accept those errors and use them to find out what areas of your learning need more work. Correct them and then move on with new knowledge.

### **Learning Math is Not a Competitive Game.**

Physicist Albert Einstein, politician Winston Churchill, and inventor Thomas Edison were all considered slow in school. Musical composer Ludwig Van Beethoven and scientist Louis Pasteur probably had learning disabilities. What all five certainly had was determination and patience to persevere. Only compete with yourself, pushing yourself forward, in learning math.

### **There is Hope for Those with Learning Disabilities.**

If you really have a hard time learning, you might ask your local college or a private learning specialist to assess you for a learning disability. Many colleges and universities do free testing and training for their students. You can also purchase this kind of assistance from private consultants. Much is now known about learning disabilities and how to help people who have them. Learning



disabilities often become just learning differences as students learn to honor and use their own thinking and learning styles.

### **Math Success and Test-Taking Success are Not the Same.**

Many math students understand and can work math problems, but have difficulty in test-taking situations. It is possible to know math and still fail exams. These people may find Section 4, Test Preparation very helpful. Conscious practice of both math skills and test-taking skills can make a big difference in your score.

### **Resources are Available.**

Resources exist for all types of math. You will need to decide whether you will work on your math skills independently or with the help of some structure such as a math course or a tutor. Different strategies may work better at different stages in your progress.

Your local community college has inexpensive math courses. Some colleges even have math courses specifically for water and wastewater professionals. Professional organizations sponsor training conferences and seminars which include math courses specific to the field. Many agencies can provide in-house training and many agencies will provide individual help with all aspects of test taking.

#### **Community Colleges**

Community colleges offer several types of services including:

- Math Placement Testing
- Math Courses
- Water Utility Science Courses
- Math Anxiety Reduction Courses
- Testing and Training for those with Learning Disabilities

#### **Professional Organizations**

Organizations such as the California Water Environment Association (CWEA), American Water Works Association, and American Public Works Association also provide opportunities to practice your math skills and network with others:

- Technical Certification Training Classes and Annual Conferences
- CWEA Northern and Southern Regional Training Conferences
- CWEA Study Guides

### **At Work**

Ask for help and suggestions from others who have taken math courses or are skilled in the work area similar to the one you are trying to prepare or improve. Ask your supervisor for advice on how to prepare and how much time on the job you can have to prepare. Ask your supervisor to provide training classes for the areas that you are wanting to improve. Ask those managing other departments, agencies, or local professional organizations for help in getting the training you need.

### **Materials**

Any basic math book or instructional manual that you can beg, borrow, or buy, including:

- Courses from Ken Kerri, Office of Water Programs, California State University, Sacramento, 6000 J Street, Sacramento, CA 95819
- Price, Joanne Kirkpatrick. *Basic Math Concepts for Water and Wastewater Plant Operators, 2nd Edition*. Lancaster, Pennsylvania: Technomic, 1991; currently CRC Press LLC.
- Smith, Richard Manning. *Mastering Mathematics: How to Be a Great Math Student*, 3rd Ed. Pacific Grove, CA: Brooks/Cole, 1998.
- Zaslavsky, Claudia. *Fear of Math*. New Brunswick, NJ: Rutgers University Press, 1994.

## **Practice Problem Solving Strategies**

Wastewater math deals with only a handful of basic types of problems that involve moving liquids and semi-solids from place to place, and manipulating, storing, and treating these substances along the way.

So basically, understanding area, volume, slope, rates, concentrations, costs, and time elements that occur in wastewater treatment 24 hours per day, 365 days per year, pretty much covers what you need to know.

### **Units and Arithmetic**

All wastewater math problems can be solved by simple arithmetic—adding, subtracting, multiplying, and dividing. You can become proficient with



## Appendix A: You and Wastewater Math

wastewater math by paying careful attention to the units in the problems as you write down your strategies, and then using a calculator to do the needed arithmetic.

### Units

Units such as cubic feet, gallons, gpm, and mgd are important in wastewater math problems. Paying attention to the units will tell you whether to multiply or divide. Also, the units will often help you know what numbers to multiply or divide.

Notice in each example that doing math operations on the units produces the correct units in the answer. Many people do the math on the units first to figure out the correct procedure before they ever do the math on the numbers.

### Multiplying

Multiplying is important. There are several symbols for multiplication. They are •, x, and ().

For example,

$$2 \cdot 3 = 2 \times 3 = (2)(3) = 6$$

### Dividing

Dividing is important to wastewater math because units often used such as MGD, cfs, ppm, GPM, psi, mg/L, GPD/sq ft, and % are really division problems.

“Per” stands for “divided by.”

$$\text{MGD} = \frac{\text{millions gallons}}{\text{day}}$$

$$\text{cfs} = \frac{\text{cubic feet}}{\text{second}}$$

$$\text{ppm} = \frac{\text{parts}}{\text{million}}$$

$$\text{GPM} = \frac{\text{gallons}}{\text{minute}}$$

$$\text{psi} = \frac{\text{pounds}}{\text{square inch}}$$

$$\text{mg/L} = \frac{\text{milligrams}}{\text{Liter}}$$

$$\text{GPD/square foot} = \frac{\text{gallons/day}}{\text{square foot}}$$

$$10\% = \text{ten percent} = \frac{10}{100}$$

## Example Problems

### Example 1

Plant No. 1 measured a flow of 3.5 million gallons in half a day. If the peak flow (hydraulic) capacity of the plant is 8 mgd, is there need for concern?

Using the conversion factor

$$\text{mgd} = \frac{\text{million gallons}}{\text{day}}$$

divide 3.5 million gallons by half a day.

$$\text{mgd} = \frac{3.5 \text{ million gallons}}{.5 \text{ day}} = 7 \text{ mgd}$$

7 mgd is less than the peak flow capacity, 8 mgd. There is no need for concern yet.

### Example 2

- a. Find the number of gallons in 10 cubic feet.

Since we can pour 7.48 gallons into a 1 cubic foot container, that means that 7.48 gallons = 1 cubic foot. We can use either factor:

$$\frac{7.48 \text{ gal}}{1 \text{ cu ft}} \text{ or } \frac{1 \text{ cu ft}}{7.48 \text{ gal}}$$

to convert cubic feet units into gallons or vice versa

$$\frac{10 \text{ cu ft}}{1} \times \frac{7.48 \text{ gal}}{1 \text{ cu ft}} = \frac{(10 \text{ cu ft})(7.48 \text{ gal})}{1 \text{ cu ft}}$$

$$= 74.8 \text{ gal}$$

Notice that using the first factor allows the unit “cu ft” to cancel out leaving the answer in gallons.

- b. Find the number of cubic feet in 10 gallons. Notice that using the second factor allows the unit “gal” to cancel out leaving the answer in cubic feet.

$$\frac{10 \text{ gal}}{1} \times \frac{1 \text{ cu ft}}{7.48 \text{ gal}} = \frac{(10 \text{ gal})(1 \text{ cu ft})}{7.48 \text{ gal}}$$

$$= 1.34 \text{ cu ft}$$

You will notice how important it was in these examples to consider the units in deciding whether to multiply or divide by 7.48.



**Example 3**

- a. Find the detention time for a basin with 675,460 gal if the flow is 1,000,000 gal/day.

Flow is always a rate which is division. Units like gpd or cfs are both division.

The formula for the basin detention time is:

$$Dt = \frac{\text{volume}}{\text{flow}}$$

$$Dt = \frac{675,460 \text{ gal}}{1,000,000 \text{ gal/day}}$$

$$= \frac{675,460 \text{ gal}}{1} \times \frac{\text{day}}{1,000,000 \text{ gal}} = 0.675 \text{ days}$$

- b. Find the detention time for a 426 cubic foot basin if the flow is 1,000 cfs.

$$Dt = \frac{426 \text{ cu ft}}{1,000 \text{ cfs}} = \frac{426 \text{ cu ft}}{1,000 \text{ cu ft/sec}}$$

$$= \frac{426 \text{ cu ft}}{1} \times \frac{\text{sec}}{1,000 \text{ cu ft}} = 0.426 \text{ sec}$$

**Example 4**

Find the number of gallons of an 11% polymer needed to produce 100 gallons of a 0.75% solution.

Use the formula  $C_1V_1=C_2V_2$  where C=concentration or % and V=volume.

You can let the volume you are looking for (i.e. the number of gallons of 11% polymer) be represented by  $V_1$ . Then  $C_1=11\%$  or 0.11,  $C_2=0.75\%$  or 0.0075, and  $V_2=100$  gallons.

Using the formula  $C_1V_1=C_2V_2$ , you have  $(0.11)(V_1) = (0.0075)(100)$

Notice to find  $V_1$ , you do the opposite of multiplying (i.e. dividing) by 0.11 on both sides. You then have

$$\frac{(0.11)(V_1)}{0.11} = \frac{(0.0075)(100)}{0.11}$$

and using a calculator,  $V_1=6.82$ . So, the amount needed is 6.82 gallons.

**Example 5**

How many hours will it take to empty a 43,000 cubic foot tank if it empties at a rate of 2.7 cubic feet per second?

Notice that dividing 43,000 cubic feet by 2.7 cubic feet per second would make the cubic feet unit cancel out. This would give us the time in seconds. To convert seconds into hours, use the factors

$$\frac{1 \text{ min}}{60 \text{ sec}} \text{ and } \frac{1 \text{ hr}}{60 \text{ min}}$$

The work is given below. Notice how the units cancel out leaving the answer in hours.

$$\text{Time} = \frac{43,000 \text{ cu ft}}{2.7 \text{ cu ft/sec}} \times \frac{1 \text{ min}}{60 \text{ sec}} \times \frac{1 \text{ hr}}{60 \text{ min}}$$

$$= 4.42 \text{ hr}$$

**Example 6**

Find the number of gallons of water in a rectangular basin 200 feet long, 50 feet wide, and 12 feet deep.

First, find the volume of the rectangular basin by multiplying length by width by height.  $\text{Volume} = (200 \text{ ft})(50 \text{ ft})(12 \text{ ft}) = 120,000$  cubic feet or cu ft or  $\text{ft}^3$ .

You now have a problem similar to Example 2. How many gallons are there in 120,000 cubic feet? Use the factor

$$\frac{7.48 \text{ gal}}{1 \text{ cu ft}}$$

to convert cubic feet into gallons.

$$\text{Volume} = \frac{120,000 \text{ cu ft}}{1} \times \frac{7.48}{1 \text{ cu ft}}$$

$$= 897,600 \text{ gal}$$



## Appendix A: You and Wastewater Math

### Example 7

A cylindrical tank is full to 3 feet below the top at 10 a.m. and empty at 4 p.m. If the tank is 50 feet tall with a diameter of 70 feet, find the volume (in gallons) of the liquid at 10 a.m. and the rate of flow from the tank in gallons per minute.

For a math problem with many words, I recommend always first writing down what you are trying to find:

- (1) First, find the number of gallons of water in the tank at 10 a.m.
- (2) Second, find the rate of flow in gal/min.

Drawing a sketch helps some people understand the problem and helps to keep track of the data.

I also like to write down and interpret the details that are given to me like:

Full to 3 ft below the top at 10 a.m.

Empty at 4 p.m.

Takes 6 hours to empty

- a. First, to find the volume in gallons at 10 a.m., use the formula for volume of a cylindrical tank which is  $V=(\text{area of the base}) \times (\text{height})$ .

To find the area of the base of the tank which is a circle, multiply 0.785 times the diameter squared.

$$\begin{aligned}\text{So, the area of the base} &= 0.785(70^2) \\ &= 3,846.5 \text{ sq ft.}\end{aligned}$$

The height at 10 a.m. is 47 feet because the tank is filled to 3 feet below the top.

$$\begin{aligned}\text{Volume} &= (\text{area of the base})(\text{height}) \\ &= (3846.5 \text{ ft}^2)(47 \text{ ft}) = 180,785.5 \text{ ft}^3\end{aligned}$$

However, you want the volume in gallons so use the factor

$$\frac{7.48 \text{ gal}}{1 \text{ cu ft}}$$

to convert.

$$\begin{aligned}\text{Volume in gallons} &= 180,785.5 \text{ ft}^3 \times \frac{7.48 \text{ gal}}{1 \text{ ft}^3} \\ &= 1,352,275.54 \text{ gal}\end{aligned}$$

- b. Second, to determine the rate of flow in gallons per minute, divide the number of gallons by the number of minutes it took the tank to empty. It took 6 hours to empty. To convert 6 hours to minutes, use  $60 \text{ min} = 1 \text{ hr}$  or factors

$$\frac{60 \text{ min}}{1 \text{ hr}} \text{ or } \frac{1 \text{ hr}}{60 \text{ min}}$$

to convert. You want the hour unit to cancel out, so you will use the first factor. The time becomes:

$$\frac{6 \text{ hrs}}{1} \times \frac{60 \text{ min}}{1 \text{ hr}} = 360 \text{ min}$$

Rate of flow in gal per minute =

$$\frac{1,352,275.54 \text{ gal}}{360 \text{ min}} = 3,756.32 \text{ gal per min}$$

### Take Charge of Your Success

The key to progress with math is to consciously take charge of your thoughts and actions. Then, instead of letting math control you, you control math and you take charge of your success.

### Recommendations

#### Ask Questions.

Be active and assertive. Learning is not a spectator sport. You cannot learn well from the sidelines. Get involved. Work problems and keep asking questions until they become clear. In classes and seminars, ask questions on confusing procedures.

#### Take It Easy.

When you get stuck working problems, hang in for a while and then take a break. Go back later, begin at the beginning with a clean sheet of paper and a different point of view. Just because you do not understand at first does not mean understanding will not come. Math learning requires time to settle into your brain. Being able to live with uncertainty for a while is a good math skill to have.

#### Keep a List.

Write down your resources (books, tutors, people to answer questions, people who understand) so that you can consult them when you get discouraged. You are not alone. Find helpful people with whom you are comfortable. Form a network with others working toward the same goals as you.



### **Find Yourself.**

Discover your own unique ways of learning. Experiment with new ones. If a method does not work, find others. Ask different people how they learn math or do a problem. They will often feel honored and pleased that you asked them and you might get a breakthrough idea.

### **Be Positive.**

Listen to what you say to yourself inside your head. It is difficult to work well if you are saying, “I will never get this” or “I cannot do math.” Change those negative messages to neutral ones like “I have not learned this *yet*” or “I cannot do this particular problem *yet*.”

### **Reward Yourself.**

Acknowledge your progress—every little bit! Pat yourself on the back for each and every problem you work. Notice what you know now that is new that you did not know two weeks ago. Maybe even write it down to document your growth.

### **Learn From Mistakes.**

Remember that errors are part of the learning process. Pay attention to them and figure out where they happened and how to fix them.

### **Keep It Real.**

Be realistic with your expectations of yourself—your math level, your life commitments, and your time constraints. Do not beat yourself up for being a human being.

### **Use Technology.**

Learn to use a calculator and use it appropriately for calculations with large numbers and decimals. Each brand of calculator is different, so keep your manual for reference. Take spare batteries to exams.

### **Start Easy.**

Practice the easier math problems to warm up each time you begin your math study. This builds confidence and strengthens those math pathways in your brain.

### **Use Paper.**

Keep scratch paper available and expect to use it for your math work. You need empty space on paper to think and do calculations.

### **Promote Emotional Well Being.**

Patience, self-care, and humor will make your math work so much easier. Your brain will work better too.

### **Be Healthy.**

You are making new connections in your brain as you practice math, so sufficient sleep and healthy foods are important. Having fresh drinking water available and breathing fresh air also helps you think better.

## **Test-Taking Strategies**

There are many actions you can take before, during, and after exams that will improve your test-taking performance and outlook. Remember that math skills and test-taking skills are different from each other. This section will help you become conscious of your thoughts and actions regarding test preparation. Use these suggestions to take charge and approach your test confidently.

If you find yourself thinking negative thoughts about your coming exam, skip to the last section and read “Negative Thinking about Exams” first.

### **Before the Exam**

#### **Work Problems.**

Diligently prepare and practice. Repeat solving problems to gain speed and confidence. This takes work and time—sometimes many hours, even days. Going in to an exam with the knowledge that you have worked lots of problems boosts confidence. Prep time is invaluable.

#### **Relax.**

Practice relaxation daily for about at least ten minutes using breathing. Sitting or lying comfortably, breathe slowly in through your nose counting to five and then out through your mouth counting to ten. If you feel dizzy, breathe normally for a while. Deep breathing activates chemicals in your body that help you relax and feel better. Any type of regular meditation, yoga, or slow stretching while breathing deeply can help facilitate your relaxation response. Practicing daily will help you control your adrenaline level during your exam. Using relaxation consciously during an exam frees up the thinking part of your brain. (Do not practice these deep breathing exercises while you are driving.)



## Appendix A: You and Wastewater Math

### **Stay Active.**

Daily walks or biking or whatever aerobic exercise you use consistently prepares your body for your exam by relieving stress and keeping your state of mind positive. Your mind and your body are connected so tightly that they are nearly the same.

### **Rehearse.**

Do a dress rehearsal for your exam. Write or have someone assist you in writing a practice test with problems and questions that you think might be on the real exam. Use questions from the diagnostic test in Section 5 of this study guide. Give yourself this practice test in an environment as close to your testing situation and schedule as possible. Time it and then correct it to learn from your errors.

### **Plan Ahead.**

Plan ahead carefully so that you will get to the exam early—do not be in a rush. Know exactly how to get there and what you will wear so that you are comfortable. You might want to wear your “lucky” shirt or bring a photograph of people who care about you and believe in you. **WHATEVER** you can do to increase your sense of comfort and security, do it. Ahead of time, pack a Testing-Taking Kit with sharp pencils, pens, a ruler, erasers, tissues or handkerchief, a bottle of water, extra calculator batteries, and anything else you think you might need that is allowed at the test.

### **Care For Your Body.**

Optimal food and rest are individual preferences. Plan these ahead of time. Some research has shown that a brisk walk before an exam has raised test results. Some research has shown that eating a few candies (not chocolate) right before an exam has raised test results. Protein appears to be essential for clear thinking. Be in charge of what happens to you before the exam. Do not let outside influences take charge of you for this little time before your test.

## **At the Exam**

### **Do a Data Dump.**

Bring a short list of formulas or facts you find difficult to remember. Look at them before the test. Visualize them going into a holding tank in your brain. Practice making them subject to recall. If you are not allowed to use notes on the exam, be sure to put the list away so that your honesty is not questioned. When you receive your test, quickly write these formulas or facts on your exam paper. Now you do not have to expend any energy trying to recall them later when you need them.

### **Ignore Others.**

Ignore all of the other people at the exam—before, during, and maybe even after. Different people have different ways of dealing with their anxiety during tests. Some people get a little hyper and try to rub off their anxiety on everyone else. Do not take on someone else’s anxiety. Your test is not a competition, so what other people do will not affect your score. Often the first person to leave an exam gets a very low score, while the last person to leave gets a very high score. Take your time. Pay no attention to other people’s behavior.

### **Breathe.**

When you feel stuck or tense, take a deep breath. Let it all go as you expel the air. (The more you have practiced relaxation and deep breathing before the exam, the more you will relax during the test.)

### **Take Time Out.**

Take short breaks during the exam to close your eyes, breathe deeply, and stretch your neck and arms. Massaging your temples, scalp, and the back of your neck will increase blood flow with oxygen to your brain to help you think better. A few isometric exercises can release tension too.

### **Use Your Subconscious Mind.**

If a problem makes no sense, read it and go on. Ideas will come to you as the problem sinks into your subconscious mind while you continue with the test.

### **Trust.**

Let each question reach into your mind for the answer. Remind yourself that you know everything you need to know for now.



### **Strategize.**

Do the easy problems and questions first. Make pencil marks by the questions to which you want to return.

### **Use Time Wisely.**

Do not work on one problem for a long time. Often a question further into the exam will act as a “key” to unlock a previous problem. Tell yourself that you have all of the time you need. Let go of the rest of your life during the exam. You can deal with all that later.

### **After the Exam, Let the Results Go.**

You have used a lot of energy and may be low and off balance. You may wish to pass up discussing the exam with others so you can take care of yourself. Going to the bathroom, drinking some water, and eating something can help you feel normal again. You may have set much of your life aside to prepare for this exam. Refresh yourself and get your life back. You can deal with the test results later when your priorities are in order again.

### **Negative Thinking About Exams**

Here are negative thoughts math students often think before test-taking. Put a check mark by the examples familiar to you. Recognizing the distorted thinking in each example can help you change negative thoughts to neutral or positive ones. If you need more assistance with overwhelming negative thoughts, I recommend the book *Feeling Good* by David Burns (WholeCare, 1999).

#### **“I Will Fail.”**

Unless you have a crystal ball and can see into the future OR unless you have made a definite plan NOT to prepare for the test OR unless you plan to “freeze up” during the exam, you have no way of knowing whether you will fail or not. Worrying about the future only takes energy from today.

#### **“I Will Panic During the Test.”**

It is not uncommon to be excited. An exam is a process during which you will experience many thoughts, feelings, and body sensations. Actors get nervous, yet they still perform. If you do panic, let panic leave you. It will. No one dies from panicking during an exam.

Preparation by practicing problems, asking questions, and reviewing gives you confidence and skills that you need. Taking a dress rehearsal test and trying to panic can help you practice dealing

with out-of-control feelings. Learning some relaxation techniques to use before and during the exam calms you and aids clear thinking. The more you prepare yourself ahead, the more you are in charge and feel relaxed.

#### **“I Cannot Do Math.”**

Math is a very broad subject involving many different skills. If you can recognize shapes, tell time, and know where the front and back of a classroom are, you can already do math. There are many more math skills that you have and many that you do not have YET. There are also many that you will never choose to acquire. Instead of thinking so absolutely about math, find areas where you can grow and learn new skills instead of paralyzing yourself with this broad generalization.

#### **“I Am Stupid.”**

Name calling is seldom productive. Occasionally you may feel stupid because you do not know something or you mess up. What really is happening is that you are being human and humans are not stupid. Educators recognize the need to change how everyone thinks about intelligence. They recognize that there are many different kinds of intelligence including:

- bodily/kinesthetic
- verbal/linguistic
- naturalist
- logical/mathematical
- visual/spatial
- interpersonal
- intrapersonal
- musical/rhythmic

This comes from the work of Howard Gardner. (Gardner, Howard. *Multiple Intelligences: The Theory in Practice*. New York: Basic Books, 1993.)

You are a wonderful combination of these talents—not just an IQ number. IQ Tests are limited because they only measure a few types of intelligence and ignore the rest. We are not all the same and cannot possibly know all there is to know in every situation. Between now and the exam, there are many questions you can get answered as well as many new skills you can practice and master if you use the skills and intelligence that you have.



## Appendix A: You and Wastewater Math

### **“I Will Forget Everything.”**

Forgetting does not mean something is gone from your mind forever. The right cue will often help you remember what you need to know. Your exam will be filled with cues—words and symbols—that will trigger formulas and ideas you have practiced.

Expecting to forget “everything” is foretelling the future and making a broad generalization. Even most people with amnesia caused by illness or injury do not forget “everything.” If you are extremely worried about your memory, *The Great Memory Book* by Karen Markowitz and Eric Jensen (The Brain Store, 1999) can be of assistance to you.

### **“Math Tests Are Tricky.”**

Math students who rely on memorizing the material rather than understanding it are usually the ones who think tests are tricky. You will use your memory to add to your understanding of how to do the math. Your math problems will contain many units such as mgd or ft<sup>3</sup> or psi. Learning how to skillfully convert back and forth between units of measure will take a lot of the trickiness away from your test problems. Practicing using your calculator will help too.

### **“There Is So Much I Do Not Know.”**

This will always be the case the rest of your life. It is the human condition. Taking a deep breath and finding the level where you can begin to learn will improve your feelings and your confidence.



## Glossary of Technical Terms

**Absolute Viscosity:** A measurement of the internal resistance, to shear, in a fluid.

**Accumulator:** A container in which fluid is stored under pressure as a source of fluid power.

**Alloy Steel:** Steel that owes its distinctive properties to elements other than carbon.

**Alternating Current (AC):** Electric current that periodically reverses its direction, rising from zero to maximum and returning to zero, then repeating the sequence in the opposite direction.

**Ambient Temperature:** The temperature of the surrounding medium, usually referred to as the temperature of the air surrounding a structure or operating device.

**Angular Misalignment:** Shafts with the axis concentric but not parallel.

**Assembly:** The joining together of two or more piping components by bolting, welding, caulking, brazing, soldering, cementing or threading into their installed location as specified by the engineering design.

**Ball Joint:** A joint that permits universal rotational movement in a piping or mechanical system.

**Base Metal:** The metal to be welded, brazed, soldered or cut. It is also referred to as the parent material.

**Bearings:** A bearing, in the mechanical terms used by millwrights and mechanics, is a support for a rotating shaft.

**Bearing, Guide (Sleeve):** The primary function of a guide bearing is to support and align members having sliding or reciprocating motion.

**Bearing, Radial:** The function of radial bearings is to support loads that act radially. These are loads acting at right angles to the shaft centerline.

**Bearing, Thrust:** The thrust bearing supports or resists loads that act axially. They may be termed endwise loads because they act parallel to the centerline, towards the shaft ends.

**Blank Flange:** A flange that is not drilled but is otherwise complete.

**Blind Flange:** A drilled flange used to close the end of a pipe. It is also known as a *dead end*.

**Brazing:** A metal joining process wherein coalescence is produced by the use of a nonferrous filler material having a melting point above 800°F but lower than that of the parent material. The filler metal is melted, distributed between closely fitted surfaces of a joint by capillary action, and adheres to the parent materials forming the weld.

**Calipers:** Adjustable instruments composed of two straight or curved legs joined at the top by a hinge. They are used to transfer measurements from a measuring tool to the work piece or from the work piece to the measuring tool.

**Caliper, Vernier:** The vernier caliper is designed to measure with greater accuracy than an ordinary caliper. The greater accuracy is possible because of the special vernier scale attached to the index line. It can measure with an accuracy of 0.001 of an inch and has separate scales, one for inside measurements and one for outside measurements.

**Cast Iron:** A generic term used for the family of high carbon-silicon-iron casting alloys including gray, white, and ductile iron.

**Cavitation:** The forming and collapsing of vapor bubbles from a low pressure to high pressure in a pumped fluid. This causes noise and may cause damage. Vapor bubbles are formed when the liquid falls below its vapor pressure at ambient temperature.

**Celsius:** The international name for the centigrade scale of temperature, on which the freezing point of water is 0°C and the boiling point is 100°.

**Centrifugal Force:** The force that causes rotating bodies to move away from the center of rotation.



## Appendix B: Glossary of Technical Terms

**Centrifugal Pump:** A pump consisting of an impeller on a rotating shaft that is in a casing having a suction connection and a discharge connection. The rotating impeller creates pressure by the velocity derived from centrifugal force.

**Circuit Breaker:** A switch device that allows manual or automatic interruption of an electrical current by tripping a switch to isolate a circuit or electrical equipment from the power source.

**Clean Water Act (CWA):** The federal Clean Water Act sets the framework for the imposition of industrial wastewater control programs on municipalities and the regulation of industrial users. Sections 307(b) and (c) of the CWA sets the authority for the U.S. EPA to establish pretreatment standards for existing and new sources discharging industrial wastewater to POTWs.

**Conductor:** Any material that will transmit electric current readily, such as wire or cable, busbar, liquid electrolyte, etc.

**Coupling (piping):** A sleeve used to connect two pipes.

**Coupling (pump):** A mechanical device usually fabricated of synthetic material, used to connect the ends of the motor shaft and the pump shaft.

**Critical Speed:** The speed of a rotating element at which resonance (natural frequency) occurs. It can destroy the rotating mass as the uncontrolled vibration level increases.

**Density:** The density of a substance is defined as the mass of the substance per unit volume. It is expressed in a variety of units.

**Efficiency:** The ratio between useful work performed and the energy expended in producing it. It is the ratio of output power divided by the input power.

**End-suction Pump:** A centrifugal pump with the suction and discharge ports located at right angles to each other.

**Expansion Joint:** A flexible piping component that absorbs thermal and/or terminal movements.

**Fahrenheit:** A temperature scale in which 32° marks the freezing point, and 212° the boiling point, of water.

**Fatigue:** The tendency for any material to fail structurally due to repeated cyclic stress at considerably less than its design strength.

**Filter:** A device which removes solid material from a liquid.

**Filter Efficiency:** The ability, expressed as a percent, of a filter to remove a specified artificial contaminant at a given concentration under specified test conditions.

**Flash point:** The temperature at which a liquid must be heated under specified conditions of the test method to give off sufficient vapor to form a mixture with air that can be ignited momentarily by a specified flame.

**Flow:** The movement of a stream of water or other fluid from place to place.

**Flow Rate:** The volume, mass or weight of a fluid passing through any conductor per unit of time.

**Flux:** A material used to dissolve, prevent accumulation of, or facilitate removal of oxides and other undesirable substances during welding, brazing or soldering.

**Frequency:** The number of cycles in a time period (usually one second). Alternating current frequency is expressed in cycles per second, termed Hertz (Hz).

**Friction:** The resistance to motion between two surfaces in contact.

**Friction Head:** The pressure expressed in pounds per square inch or feet of liquid needed to overcome the resistance to flow in the pipe and fittings.

**Galvanizing:** A process by which the surface of iron or steel is covered with a layer of zinc.

**Gas Metal Arc Welding (GMAW):** An arc welding process that employs a continuous solid filler metal (consumable) electrode. Shielding is obtained entirely from an external supplied gas or gas mixture. (Some methods of this process have been called MIG or CO<sub>2</sub> welding.)

**Gas Tungsten Arc Welding (GTAW):** An arc welding process that employs a tungsten (non-consumable) electrode. Shielding is obtained from a gas or gas mixture. Pressure may or may not be used and filler metal may or may not be used. (This process has sometimes been called TIG welding. When shielding is obtained by the use of an inert gas such as helium or argon, this process is called *inert-gas tungsten arc welding*.)



**Gauge, Pressure:** A device for registering the pressure of solids, liquids or gases. It may be graduated to register pressure in any units desired.

**Gearbox or Reducer:** A machine of different diameter gears, which connects the prime mover drive shaft to a driven piece of equipment and reduces the speed of the driven unit.

**GPD:** The rate of flow of a fluid measured in U.S. gallons per day.

**GPM:** The rate of flow of a fluid measured in U.S. gallons per minute.

**Hazardous Waste:** Any waste material that is potentially damaging to environmental health due to toxicity, ignitability, corrosivity, chemical reactivity or other reasons.

**Head:** The height of a column or body of fluid above a given point expressed in linear units. Head is often used to indicate gauge pressure. Pressure is equal to the height times the density of the fluid.

**Head Loss:** The decrease in pressure of a fluid flowing through a passage (pipe, for example), attributable to the friction between the fluid and the passage walls.

**Header:** A pipe or fitting to which a number of branch pipes are connected.

**Heat Exchanger:** A device that transfers heat through a conducting wall from one fluid to another.

**Horsepower:** A unit for measuring the power of motors or the rate of doing work. One horsepower equals 33,000 foot-pounds of work per minute (550 foot-pounds per second) or 746 watts.

**Hot Taps:** Branch piping connections made to operating pipelines, mains or other facilities while they are in operation.

**Hydrogen Sulfide(H<sub>2</sub>S):** A toxic and lethal gas produced in sewers and digesters by anaerobic decomposition. Detectable in low concentrations (%) by its characteristic “rotten egg” odor. It deadens the sense of smell in higher concentrations or after prolonged exposure. Respiratory paralysis and death may occur at concentrations as low as 0.07% by volume of air.

**Hypochlorination:** The use of sodium hypochlorite (NaOCl<sub>2</sub>) for disinfection.

**Impact Test:** A test to determine the behavior of materials when subjected to high rates of loading, usually in bending, tension or torsion. The quantity measured is the energy absorbed in breaking the specimen by a single blow, as in Charpy or Izod tests.

**Impeller:** A rotating set of vanes designed to impel rotation of a mass of fluid.

**Instrumentation:** The use of technology to control, monitor or analyze physical, chemical or biological parameters.

**Kinematic Viscosity:** The ratio of the absolute viscosity to the mass density. In the metric system, kinematic viscosity is measured in stokes or square centimeters per second.

**Lantern Ring:** A ring in line with a port in a stuffing box which provides sealing fluid. The sealing fluid also lubricates and cools the packing.

**Manifold:** A conductor that provides multiple connection ports.

**Manometer:** An instrument for measuring pressure. It usually consists of a U-shaped tube containing a liquid, the surface of which moves proportionally in one end of the tube with changes in pressure in the liquid in the other end.

**Mechanical Seal:** A seal placed on the pump shaft to prevent air from entering the pump and water from leaking from the pump along the shaft.

**Megger:** An extended ohmmeter used to measure the electrical resistance of motor insulation.

**Meter:** An instrument for measuring some quantity, such as the rate of flow of liquids, gases, or electric currents.

**Methane (CH<sub>4</sub>):** A colorless, odorless, flammable, gaseous hydrocarbon present in natural gas and formed by the anaerobic decomposition of organic matter, or produced artificially by heating carbon monoxide and hydrogen over a nickel catalyst.

**MGD:** The rate of flow of a fluid measured as one million U.S. gallons per day.

**Micrometer:** A micrometer is a type of caliper that is used for accurate measurements to 0.0001 inch. It works by keeping track of the advance of a fine-pitch screw through any number of complete turns or a fraction of a turn.



## Appendix B: Glossary of Technical Terms

**Nipple:** A piece of pipe less than 12 inches in length which may be threaded on both ends or one end and provided with ends suitable for welding or a mechanical joint. Pipe over 12 inches long is considered cut pipe.

**Nondestructive Examination or Inspection:** Inspection by methods which do not destroy the item, part, or component to determine its suitability for use.

**NPDES Permit:** National Pollutant Discharge Elimination System permit is the regulatory agency document issued by either a federal or state agency which is designed to control all discharges of pollutants from point sources into U.S. waterways. NPDES permits regulate discharges into navigable waters from all point sources of pollution, including industries, municipal wastewater treatment plants, sanitary landfills, large agricultural feedlots, and return irrigation flows.

**NPSH:** Net positive suction head is a measure of the pressure at the suction side of the pump, including atmospheric pressure and vapor pressure of the liquid being pumped.

**Orifice:** An opening with a closed perimeter in a plate, wall, or partition through which water may flow; generally used for the purpose of measurement or control of such water.

**Orifice Plate:** A plate containing an orifice. In pipes, the plate is usually inserted between a pair of flanges and the orifice is smaller in area than the cross section of the pipe.

**Packing:** Specially prepared material placed in a stuffing box around the pump shaft. The packing prevents air from entering the pump and water from leaking from the pump along the shaft.

**Parallel Misalignment:** Shafts with the axis parallel but not concentric.

**Parts per million (PPM):** The number of weight or volume units of a minor constituent present with each 1 million units of a solution or mixture.

**Pipe:** A closed conduit which diverts or conducts a fluid or gas from one location to another.

**Pipe Diameter:** The nominal or commercially designed inside diameter of a pipe.

**Pressure:** The force per unit area, usually expressed in pounds per square inch.

**Pressure, Atmospheric:** Pressure exerted by the atmosphere at any specific location. Sea level pressure is approximately 14.7 pounds per square inch absolute.

**Pressure, Differential:** The difference in pressure between any two points of a system or component.

**Pump:** A mechanical device for causing flow, for raising or lifting water or other fluid, or for applying pressure to fluids.

**Pump Curve:** A curve or curves showing the interrelationship of speed, dynamic head, capacity, brake horsepower, and efficiency of a pump.

**Pump Efficiency:** The ratio of energy converted to useful work to the energy applied to the pump shaft, or the energy difference in the water at the discharge and suction nozzles divided by the power input at the pump shaft.

**Pumping Head:** The sum of the static head and friction head on a pump discharging a given quantity of water.

**RPM:** Revolutions per minute; the means of measuring the rotational speed of machinery.

**Spatter:** In arc and gas welding, the metal particles expelled during welding that do not form part of the weld.

**Specific Gravity:** The ratio of the weight of a given volume of material or liquid to the weight of an equal volume of water.

**Stainless Steel:** An alloy of steel having unusual corrosion-resisting properties, usually imparted by nickel and chromium.

**Static Head:** The difference in distance from the surface of the suction level to the surface of the discharge level, generally given in feet.

**Static Suction Head:** The vertical distance from the source of supply, when its level is above the pump, to the centerline of the pump.

**Suction Head:** The head at the inlet to a pump; or the head below atmospheric pressure in a piping system.

**Stuffing Box:** A cavity and closure for a sealing device.

**Tack Weld:** A small weld made to hold parts of a weldment in proper alignment until the final welds are made.



**Tolerance:** The amount by which any characteristic (dimensional, electrical, physical or mechanical) may vary from that specified.

**Torque:** The rotating force produced by a motor. The units of torque may be expressed as foot-pounds, inch-pounds (English system) or newton-meter (metric system).

**Total Dynamic Head:** A measure (in feet) of the energy a pump must supply to move the desired amount of water.

**Vacuum:** Pressure less than atmospheric pressure. It is usually expressed in inches of mercury (in. Hg) as referred to the existing atmospheric pressure.

**Valve:** A device which controls fluid flow direction, pressure or flow rate.

**Valve Actuator:** The valve part(s) through which force is applied to move or position flow-directing elements.

**Vertical Turbine Pump:** A centrifugal pump, commonly a multistage diffuser, in which the pump shaft is mounted vertically.

**Viscosity:** In flowing liquids, the internal friction or internal resistance to relative motion of the fluid particles with respect to each other.

**Water Hammer:** A banging or hammering noise caused by a pressure wave oscillating in a closed conduit and rebounding off the closures at each end.

**Wear Ring:** A replaceable cylindrical ring usually made of bronze and pressed into the pump casing between the high- and low-pressure sides of the rotating impeller.



# A p p e n d i x C

## Common Acronyms and Abbreviations

AA	atomic absorption	CFR	Code of Federal Regulations
AC power	alternating current	cfs	cubic feet per second
AC	acre	CH <sub>4</sub>	Methane
AF	acre-feet	CIU	Categorical Industrial User
AF	acre-foot (feet)	CM	common mode
AFY	acre-foot per year	CMOM	Capacity Management, Operations, and Maintenance
AMSA	Association of Metropolitan Sewerage Agencies	COD	chemical oxygen demand
ANSI	American National Standards Institute	CPU	central processing unit
APHA	American Public Health Association	CRWA	California Rural Water Association
AS	activated sludge	CSP	confined-space permit
ASCE	American Society of Civil Engineers	CT	current transformer
ASME	American Society of Mechanical Engineers	CWA	Clean Water Act
ASTM	American Society for Testing and Materials	CWEA	California Water Environment Association
AWT	advanced wastewater treatment	DAF	dissolved air flotation
AWWA	American Water Works Association	DO	dissolved oxygen
BECP	Business Emergency and Contingency Plan	DOHS	California Department of Health Services
BNR	biological nutrient removal	DV/DT	( $\Delta V/\Delta T$ ) The change in voltage per change in time.
BOD <sub>5</sub>	biochemical oxygen demand after 5 days	DWF	dry weather flow
BTU	British thermal unit	DWR	Department of Water Resources
C	Celsius	EIS	Environmental Impact Statement
Cal-OSHA	California Occupational Safety and Health Act	EMF	electromotive force or voltage
Cal-EPA	California Environmental Protection Administration	EPA	U.S. Environmental Protection Agency
CBOD	carbonaceous biochemical oxygen demand	F	Fahrenheit
CCE	carbon chloroform extract	F/M	food to microorganism ratio
CCR	California Code of Regulations	ft	feet (foot)
cf	cubic feet (foot)	ft <sup>2</sup>	square foot
		ft <sup>3</sup>	cubic feet
		FTU	formazin turbidity unit
		GAC	granular activated carbon



## Appendix C: Common Acronyms and Abbreviations

gal	gallon	min	minute
GFI	ground fault interrupter	MIS	Manufacturing Information System
GPD	gallons per day	mL	milliliter
GPM	gallons per minute	MLSS	mixed liquor suspended solids
GTAW	gas tungsten arc welding	MLVSS	mixed liquor volatile suspended solids
H <sub>2</sub> S	hydrogen sulfide	MMI	Man Machine Interface
HCP&ERP	Hazard Communications Program and Emergency Response Plan	MOP	Manual of Practice
hp	horsepower	MPN	most probable number
HPLC	high-performance liquid chromatography	MS	mass spectrometer
Hz	Hertz	MSDS	Material Safety Data Sheets
IC	ion chromatograph	MTBF	mean time between failures
ICP	inductively coupled plasma	MTTR	mean time to repair
IEEE	Institute of Electrical and Electronics Engineers	N	normal
IIPP	Injury and Illness Prevention Plan	NEC	National Electrical Code
IML	Interface Management Language	NEMA	National Electrical Manufacturers Association
JTU	Jackson Turbidity Unit	NEPA	National Environmental Policy Act
K	Kilo, a prefix meaning 1,000	NM	Normal Mode
KVA	kilovolt amperes	NOCA	National Organization for Competency Assurance
kw	kilowatt	NOD	nitrogenous oxygen demand
kwh	kilowatt hour	NPDES	National Pollutant Discharge Elimination System
L	liter	NPSH	net positive suction head
lb	pound	NTU	nephelometric turbidity unit(s)
M	Mega, a metric prefix meaning 1,000,000	O&M	operation and maintenance
m	meter	OCT	Operator Certification Test (State of California)
M	mole or molar	OMR	operations, maintenance, and replacement
MA	millamps	OOC	Office of Operator Certification (SWRCB)
MBAS	methylene blue active substance	OSHA	Occupational Safety and Health Administration/Act
MCL	maximum contaminant level	OTE	oxygen transfer efficiency
MCLG	maximum contaminant level goal	P	Pico, a metric prefix meaning one millionth of a millionth, or one trillionth (10 <sup>-12</sup> )
MCRT	mean cell residence time	PC	personal computer
MDL	method detection limit		
MG	million gallons		
mg	milligram		
mg/L	milligrams per liter		
MGD	million gallons per day		



## Appendix C: Common Acronyms and Abbreviations

PCB	polychlorinated biphenyls	SWRCB	(California) State Water Resources Control Board
pH	potential of hydrogen	TAC	Technical Advisory Committee
P&ID	pipng and instrumentation diagram	TC	total carbon
PID	proportional gain, integral action time and derivative action time	TCP	Technical Certification Program
PLC	Programmable Logic Controller	TDS	total dissolved solids
POTW	Publicly Owned Treatment Works	TF	trickling filter
PPB	parts per billion	THD	total harmonic distortion
PPE	Personal Protective Equipment	TIC	total inorganic carbon
PPM	parts per million	TMDL	total maximum daily load
prct	percent	TOC	total organic carbon
psi	pound per square inch	TOD	total oxygen demand
PSIA	pounds per square inch absolute	TS	total solids
PSID	pounds per square inch differential	TSS	total suspended solids
PSIG	pounds per square inch gage	TU	turbidity unit
PVC	polyvinyl chloride (pipe)	μ	micro, a metric prefix meaning one millionth
QA/QC	quality assurance/quality control	UPS	uninterruptible power supply
RAS	return activated sludge	USB	universal serial bus
RBC	rotating biological contactor	USEPA	United States Environmental Protection Agency
RCP	reinforced concrete pipe	V	volt
RFI	Radio Frequency Interference	VAC	volts of alternating current
RMS	root mean square	VCP	vitrified clay pipe
RTD	resistance temperature device	VFD	variable frequency drive
RWQCB	Regional Water Quality Control Board (State of California)	VOC	volatile organic chemicals
SCADA	Supervisory Control and Data Acquisition	VOM	volt Ohm meter
SCR	semiconductor (or silicon) controlled rectifier	VSR	volatile solids reduction
SD	standard deviation	VSS	volatile suspended solids
SDI	sludge volume index	W	watt
sec	second	WAN	wide area network
SI	System Internationale D'Unites (metric units)	WEF	Water Environment Federation
SS	suspended solids	WRP	water reclamation plant
SSO	sanitary sewer overflow	WWF	wet weather flow
SVI	sludge volume index	WWTF	wastewater treatment facility
SVR	sludge volume ratio	WWTP	wastewater treatment plant (same as POTW)
		yr	year



CWEA is pleased that you have purchased this book.

We want to remind you that this book is one of many resources available to assist you, and we encourage you to identify and utilize the other resources in preparing for your next test.

Your comments, questions, and suggestions are welcome.



**California  
Water  
Environment  
Association**

7677 Oakport Street, Suite 600  
Oakland, CA 94621-1935  
Ph: 510-382-7800  
Fx: 510-382-7810  
Em: [tcp@cwea.org](mailto:tcp@cwea.org)  
[www.cwea.org](http://www.cwea.org)